



SICUREZZA

5 perni: oltre 5.000 combinazioni
Resistente al grimaldello
Camma DIN 30° resistente alla spinta



CHIAVE

Chiave a cresta in ottone nichelato



MATERIALI

Corpo in lega di alluminio ceramizzato ad altissima resistenza
Barilotto con guida-chiave in ottone nichelato
Perni, controperni e molle in acciaio inox
Camma DIN in acciaio sinterizzato autolubrificante









Testato 96 ore in nebbia salina
Durabilità oltre 100.000 cicli



SISTEMISTICA

Impianti speciali KA - MK - GMK - CL
Per un sistema MK con alto livello di sicurezza: 500 possibili cifrature (tranne cod. 120.20.20 - 120.23.23 - 121.20.10 - 121.23.10 - 123.23.23P)

PROGETTATI E CERTIFICATI SECONDO LA NORMA EUROPEA

UNI EN 1303:15 - BS EN 1303:15 - ICIM 0039CS							
1	6	0	A	0	C	2	0
							

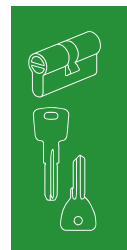

CATEGORIA D'USO

1 = destinato all'utilizzo da parte di persone che esercitano grande cura e con scarsa possibilità di uso improprio



DURABILITÀ

6 = 100.000 cicli



MASSA DELLA PORTA

0 = nessun requisito richiesto



IDONEITÀ ALL'USO SU PORTE TAGLIAFUOCO/ANTIFUMO

A = adatto a porte antifumo



SICUREZZA PER LE PERSONE

0 = nessun requisito richiesto



RESISTENZA ALLA CORROSIONE E TEMPERATURA

C = alta resistenza alla corrosione; resistenza alle temperature estreme da -25°C a +65°C



SICUREZZA DELLA CHIAVE

2 = oltre 5.000 combinazioni



RESISTENZA ALL'ATTACCO

0 = nessun requisito di resistenza alla foratura e all'attacco meccanico

DOPPIO CILINDRO

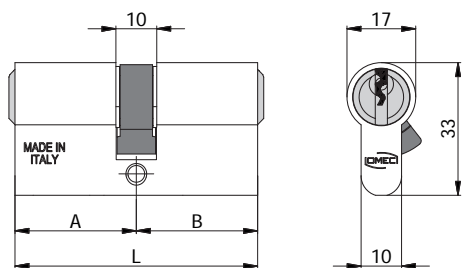

CARATTERISTICHE COSTRUTTIVE:

Corpo in alluminio ad alta resistenza - Barilotti in ottone nichelato con guida-chiave - Perni e controperni in acciaio inox - Molle in acciaio inox - Camma DIN disassata di 30° in acciaio autolubrificante - Chiavi in ottone nichelato.

FUNZIONAMENTO:

Rotazione della chiave di 360° - Le chiavi sono dipendenti e non possono azionare il cilindro se dall'altro lato é stata inserita e ruotata la chiave.

PARTI IN DOTAZIONE:

3 chiavi.

VARIANTI A RICHIESTA:

Impianti speciali KA-MK-GMK-CL.

COD.	EX COD.	L	A	B					
120.20.20	120/01 L	40	20	20	3	105/03	0,11	1	10
120.23.23	120/02 L	47	23,5	23,5	4	105/04	0,12	1	10
120.27.27	120/03 L	54	27	27	5	105/05	0,13	1	10
120.27.33	120/05 L	60	27	33	5	105/05	0,14	1	10
120.30.30	120/04 L	60	30	30	5	105/05	0,14	1	10
120.27.37	120/10 L	64	27	37	5	105/05	0,14	1	10
120.30.35	120/11 L	65	30	35	5	105/05	0,14	1	10
120.27.43	120/07 L	70	27	43	5	105/05	0,15	1	10
120.30.40	120/14 L	70	30	40	5	105/05	0,15	1	10
120.35.35	120/06 L	70	35	35	5	105/05	0,15	1	10
120.30.45	120/15 L	75	30	45	5	105/05	0,16	1	10
120.35.40	120/16 L	75	35	40	5	105/05	0,16	1	10
120.27.53	120/09 L	80	27	53	5	105/05	0,17	1	10
120.30.50	120/18 L	80	30	50	5	105/05	0,17	1	10
120.35.45	120/17 L	80	35	45	5	105/05	0,17	1	10
120.40.40	120/08 L	80	40	40	5	105/05	0,17	1	10
120.30.55	120/23 L	85	30	55	5	105/05	0,17	1	10
120.35.50	120/28 L	85	35	50	5	105/05	0,17	1	10
120.40.45	120/19 L	85	40	45	5	105/05	0,17	1	10
120.30.60	120/24 L	90	30	60	5	105/05	0,18	1	5
120.35.55	120/29 L	90	35	55	5	105/05	0,18	1	5
120.40.50	120/20 L	90	40	50	5	105/05	0,18	1	5
120.45.45	120/21 L	90	45	45	5	105/05	0,18	1	5
120.30.65	120/25 L	95	30	65	5	105/05	0,19	1	5
120.35.60	120/30 L	95	35	60	5	105/05	0,19	1	5
120.40.55	120/32 L	95	40	55	5	105/05	0,19	1	5
120.45.50	120/36 L	95	45	50	5	105/05	0,19	1	5
120.43.53	120/12 L	96	43	53	5	105/05	0,20	1	5
120.30.70	120/26 L	100	30	70	5	105/05	0,20	1	5
120.35.65	120/31 L	100	35	65	5	105/05	0,20	1	5
120.40.60	120/33 L	100	40	60	5	105/05	0,20	1	5
120.45.55	120/37 L	100	45	55	5	105/05	0,20	1	5
120.50.50	120/22 L	100	50	50	5	105/05	0,20	1	5
120.30.75	120/42 L	105	30	75	5	105/05	0,21	1	5
120.45.60	120/43 L	105	45	60	5	105/05	0,21	1	5
120.53.53	120/13 L	106	53	53	5	105/05	0,21	1	5
120.30.80	120/27 L	110	30	80	5	105/05	0,21	1	5
120.40.70	120/34 L	110	40	70	5	105/05	0,21	1	5
120.45.65	120/46 L	110	45	65	5	105/05	0,21	1	5
120.50.60	120/38 L	110	50	60	5	105/05	0,21	1	5
120.55.55	120/45 L	110	55	55	5	105/05	0,21	1	5
120.50.65	120/44 L	115	50	65	5	105/05	0,22	1	5
120.30.90	120/41 L	120	30	90	5	105/05	0,23	1	5
120.40.80	120/35 L	120	40	80	5	105/05	0,23	1	5
120.50.70	120/40 L	120	50	70	5	105/05	0,23	1	5
120.60.60	120/39 L	120	60	60	5	105/05	0,23	1	5
120.**.**.N									Finitura Nera a richiesta
120.**.**.T									Finitura Ottone a richiesta

MEZZO CILINDRO



CARATTERISTICHE COSTRUTTIVE:

Corpo in alluminio ad alta resistenza - Barilotto in ottone nichelato con guida-chiave - Perni e controperni in acciaio inox - Molle in acciaio inox - Camma DIN disassata di 30° in acciaio autolubrificante - Chiavi in ottone nichelato.

FUNZIONAMENTO:

Rotazione della chiave di 360°.





PARTI IN DOTAZIONE:

3 chiavi.

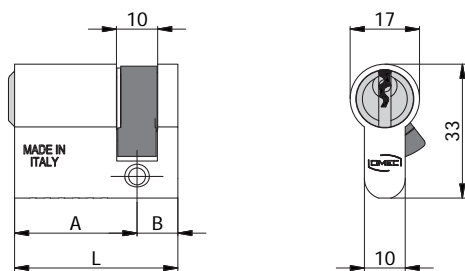
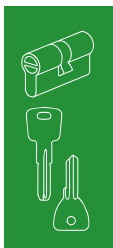
VARIANTI A RICHIESTA:

Impianti speciali KA-MK-GMK-CL.



COD.	EX COD.	L	A	B				
121.20.10	121/01 L	30	20	10	3	105/03	0,08	1 10
121.23.10	121/02 L	33,5	23,5	10	4	105/04	0,09	1 10
121.27.10	121/03 L	37	27	10	5	105/05	0,09	1 10
121.30.10	121/04 L	40	30	10	5	105/05	0,10	1 10
121.33.10	121/05 L	43	33	10	5	105/05	0,10	1 10
121.43.10	121/07 L	53	43	10	5	105/05	0,11	1 10
121.60.10	121/24 L	70	60	10	5	105/05	0,14	1 10
121.70.10	121/26 L	80	70	10	5	105/05	0,14	1 10
121.87.10	121/12 L	97	87	10	5	105/05	0,17	1 5
121.97.10	121/13 L	107	97	10	5	105/05	0,18	1 5
121.**.10.N		Finitura Nera a richiesta						
121.**.10.T		Finitura Ottone a richiesta						

DOPPIO CILINDRO CON POMOLO



CARATTERISTICHE COSTRUTTIVE:

Corpo in alluminio ad alta resistenza - Barilotto in ottone nichelato con guida-chiave - Perni e contoperni in acciaio inox - Molle in acciaio inox - Camma DIN disassata di 30° in acciaio autolubrificante - Pomolo in nylon nero - Chiavi in ottone nichelato.

FUNZIONAMENTO:

Rotazione della chiave o del pomolo di 360°.

PARTI IN DOTAZIONE:

3 chiavi.

VARIANTI A RICHIESTA:

Impianti speciali KA-MK-GMK-CL.

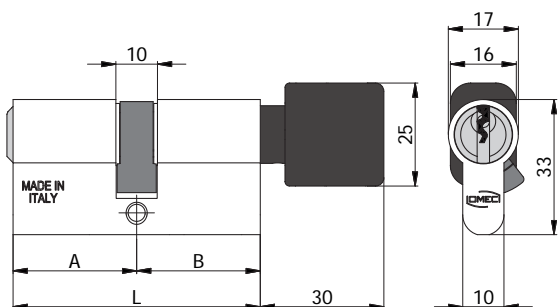

COD.	EX COD.	L	A	B			
123.23.23P	123/02 L	47	23,5	23,5	4	105/04	0,13 1 10
123.27.27P	123/03 L	54	27	27	5	105/05	0,15 1 10
123.27.33P	123/05 L	60	27	33	5	105/05	0,16 1 5
123.30.30P	123/04 L	60	30	30	5	105/05	0,16 1 5
123.33.27P	123/06 L	60	33	27	5	105/05	0,16 1 5
123.27.43P	123/08 L	70	27	43	5	105/05	0,17 1 5
123.35.35P	123/07 L	70	35	35	5	105/05	0,17 1 5
123.43.27P	123/09 L	70	43	27	5	105/05	0,17 1 5
123.27.53P	123/11 L	80	27	53	5	105/05	0,19 1 5
123.40.40P	123/10 L	80	40	40	5	105/05	0,19 1 5
123.53.27P	123/12 L	80	53	27	5	105/05	0,19 1 5
123.**.**P.N		Finitura Nera a richiesta					
123.**.**P.T		Finitura Ottone a richiesta					

DOPPIO CILINDRO CON POMOLO



CARATTERISTICHE COSTRUTTIVE:

Corpo in alluminio ad alta resistenza - Barilotto in ottone nichelato con guida-chiave - Perni e contoperni in acciaio inox - Molle in acciaio inox - Camma DIN disassata di 30° in acciaio autolubrificante - Pomolo in lega speciale cromo satinata. - Chiavi in ottone nichelato.

FUNZIONAMENTO:

Rotazione della chiave o del pomolo di 360°.



PARTI IN DOTAZIONE:

3 chiavi.

VARIANTI A RICHIESTA:

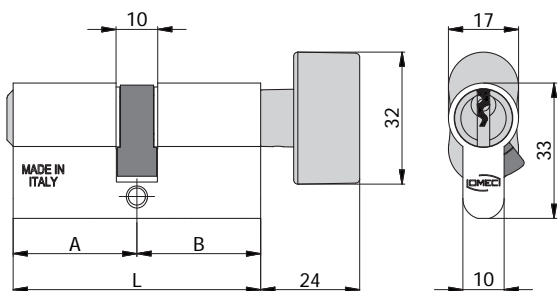
Impianti speciali KA-MK-GMK-CL.



COD.	EX COD.	L	A	B				
123.23.23B	123/02B L	47	23,5	23,5	4	105/04	0,17	1 10
123.27.27B	123/03B L	54	27	27	5	105/05	0,19	1 10
123.27.33B	123/05B L	60	27	33	5	105/05	0,20	1 5
123.30.30B	123/04B L	60	30	30	5	105/05	0,20	1 5
123.33.27B	123/06B L	60	33	27	5	105/05	0,20	1 5
123.27.43B	123/08B L	70	27	43	5	105/05	0,21	1 5
123.35.35B	123/07B L	70	35	35	5	105/05	0,21	1 5
123.43.27B	123/09B L	70	43	27	5	105/05	0,21	1 5
123.27.53B	123/11B L	80	27	53	5	105/05	0,23	1 5
123.40.40B	123/10B L	80	40	40	5	105/05	0,23	1 5
123.53.27B	123/12B L	80	53	27	5	105/05	0,23	1 5
123.**.**B.N		Finitura Nera a richiesta						
123.**.**B.T		Finitura Ottone a richiesta						

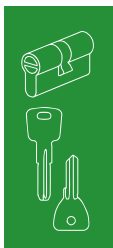

MEZZO CILINDRO CON POMOLO



CARATTERISTICHE COSTRUTTIVE:

Corpo in alluminio ad alta resistenza - Camma DIN disassata di 30°
in acciaio autolubrificante - Pomolo in nylon nero.

FUNZIONAMENTO:

Rotazione del pomolo di 360°.

PARTI IN DOTAZIONE:

/

VARIANTI A RICHIESTA:

/

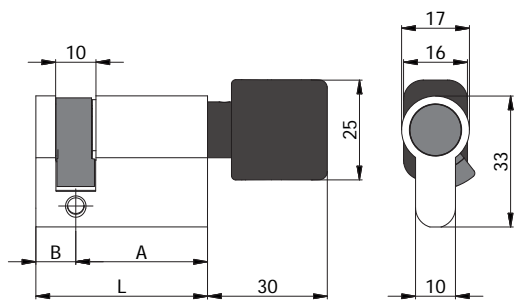

COD.	EX COD.	L	A	B	kg		
124.23P.10	124/02 L	33,5	23,5	10	0,06	1	10
124.27P.10	124/03 L	37	27	10	0,08	1	10
124.30P.10	124/04 L	40	30	10	0,09	1	10
124.33P.10	124/05 L	43	33	10	0,09	1	10
124.43P.10	124/07 L	53	43	10	0,10	1	10
124.**P.**.N		Finitura Nera a richiesta					
124.**P.**.T		Finitura Ottone a richiesta					

MEZZO CILINDRO CON POMOLO



CARATTERISTICHE COSTRUTTIVE:

Corpo in alluminio ad alta resistenza - Camma DIN disassata di 30° in acciaio autolubrificante - Pomolo in lega speciale cromo satinata.

FUNZIONAMENTO:

Rotazione del pomolo di 360°.

PARTI IN DOTAZIONE:

/

VARIANTI A RICHIESTA:

/

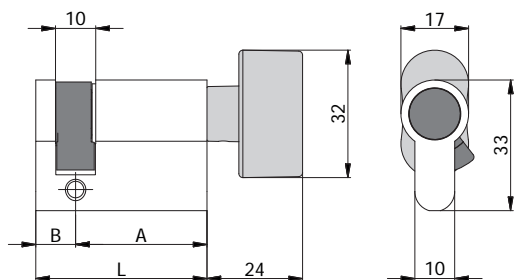
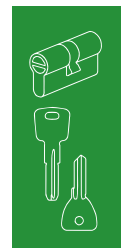

COD.	EX COD.	L	A	B	kg		
124.23B.10	124/02B L	33,5	23,5	10	0,10	1	10
124.27B.10	124/03B L	37	27	10	0,12	1	10
124.30B.10	124/04B L	40	30	10	0,13	1	10
124.33B.10	124/05B L	43	33	10	0,13	1	10
124.43B.10	124/07B L	53	43	10	0,14	1	10
124.65B.10	124/25B L	75	65	10	0,17	1	5
124.70B.10	124/26B L	80	70	10	0,17	1	5
124.**B.**N	Finitura Nera a richiesta						
124.**B.**T	Finitura Ottone a richiesta						

DOPPIO CILINDRO PER PORTE DA BAGNO



CARATTERISTICHE COSTRUTTIVE:

Corpo in alluminio ad alta resistenza - Barilotto in ottone nichelato - Camma DIN disassata di 30° in acciaio autolubrificante - Pomolo in nylon nero.

FUNZIONAMENTO:

Rotazione del barilotto o del pomolo di 360°.

PARTI IN DOTAZIONE:

/

VARIANTI A RICHIESTA:

/

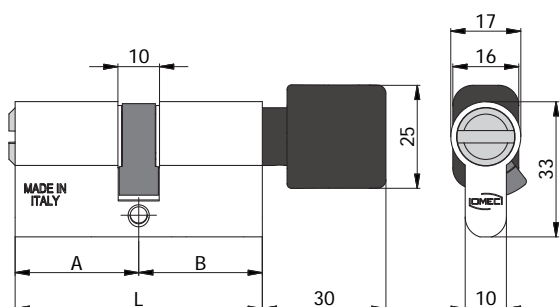

COD.	EX COD.	L	A	B	kg		
125.27.27P	125/03 L	54	27	27	0,15	1	10
125.27.33P	125/05 L	60	27	33	0,16	1	5
125.30.30P	125/04 L	60	30	30	0,16	1	5
125.35.35P	125/07 L	70	35	35	0,17	1	5
125.**.**P.N	Finitura Nera a richiesta						
125.**.**P.T	Finitura Ottone a richiesta						

DOPPIO CILINDRO PER PORTE DA BAGNO



CARATTERISTICHE COSTRUTTIVE:

Corpo in alluminio ad alta resistenza - Barilotto in ottone nichelato - Camma DIN disassata di 30° in acciaio autolubrificante - Pomolo in lega speciale cromo satinata.

FUNZIONAMENTO:

Rotazione del barilotto o del pomolo di 360°.

PARTI IN DOTAZIONE:

/

VARIANTI A RICHIESTA:

/

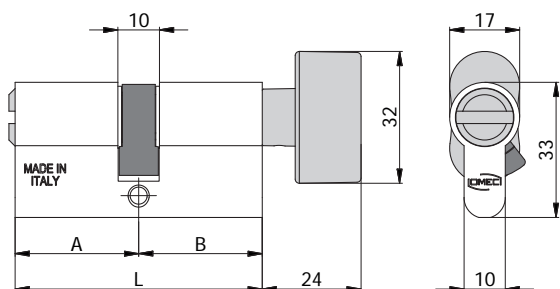

COD.	EX COD.	L	A	B	kg		
125.27.27B	125/03B L	54	27	27	0,19	1	10
125.27.33B	125/05B L	60	27	33	0,20	1	5
125.30.30B	125/04B L	60	30	30	0,20	1	5
125.35.35B	125/07B L	70	35	35	0,21	1	5
125.**.**B.N	Finitura Nera a richiesta						
125.**.**B.T	Finitura Ottone a richiesta						

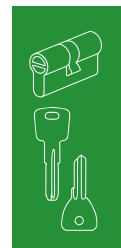



SICUREZZA

6 perni : oltre 30.000 combinazioni
Resistente al grimaldello
Camma DIN 30° resistente alla spinta
Versione frizionata con funzione di emergenza



MATERIALI

Corpo in lega di alluminio ceramizzato ad altissima resistenza
Barilotto con guida-chiave in ottone nichelato
Perni, controperni e molle in acciaio inox
Camma in acciaio sinterizzato autolubrificante

Testato 96 ore in nebbia salina
Durabilità oltre 100.000 cicli



CHIAVE REVERSIBILE

Chiave piatta reversibile in alpacca con collo allungato compatibile con borchie di protezione



CARTA DI PROPRIETA'

Security card con codice per la duplicazione



COPIA CANTIERE

Chiave cantiere in ottone disabilitata dopo l'inserimento della chiave proprietario



ERGONOMIA









Cover con impugnatura ergonomica removibile ed intercambiabile, disponibile in vari colori



SISTEMISTICA

impianti speciali KA - MK - GMK - CL
Per un sistema MK con alto livello di sicurezza: 2.000 possibili cifrature

PROGETTATI E CERTIFICATI SECONDO LA NORMA EUROPEA

UNI EN 1303:15 - BS EN 1303:15 - ICIM 0039CS							
1	6	0	A	0	C	5	0
							

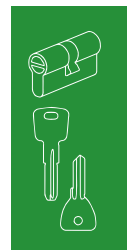

CATEGORIA D'USO
1 = destinato all'utilizzo da parte di persone che esercitano grande cura e con scarsa possibilità di uso improprio



DURABILITÀ
6 = 100.000 cicli



MASSA DELLA PORTA
0 = nessun requisito richiesto



IDONEITÀ ALL'USO SU PORTE TAGLIAFUOCO/ANTIFUMO
A = adatto a porte antifumo



SICUREZZA PER LE PERSONE
0 = nessun requisito richiesto



RESISTENZA ALLA CORROSIONE E TEMPERATURA
C = alta resistenza alla corrosione; resistenza alle temperature estreme da -25°C a +65°C



SICUREZZA DELLA CHIAVE
5 = oltre 30.000 combinazioni



RESISTENZA ALL'ATTACCO
0 = nessun requisito di resistenza alla foratura e all'attacco meccanico

DOPPIO CILINDRO

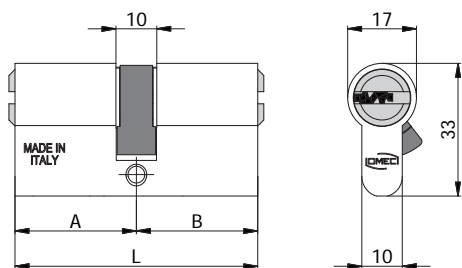

CARATTERISTICHE COSTRUTTIVE:

Corpo in alluminio ad alta resistenza - Barilotti in ottone nichelato con guida-chiave - Perni e controperni in acciaio inox - Molle in acciaio inox - Camma DIN disassata di 30° in acciaio autolubrificante - Chiavi piatte reversibili in alpaca con numero di codice.

FUNZIONAMENTO:



Rotazione della chiave di 360° - Le chiavi sono dipendenti e non possono azionare il cilindro se dall'altro lato é stata inserita e ruotata la chiave.

PARTI IN DOTAZIONE:

3 chiavi.

VARIANTI A RICHIESTA:

Impianti speciali KA-MK-GMK-CL.

COD.	EX COD.	L	A	B					
220.30.30	2120/04 L	60	30	30	6	2020/06	0,16	1	10
220.30.35	2120/11 L	65	30	35	6	2020/06	0,16	1	10
220.30.40	2120/14 L	70	30	40	6	2020/06	0,17	1	10
220.35.35	2120/06 L	70	35	35	6	2020/06	0,17	1	10
220.30.45	2120/15 L	75	30	45	6	2020/06	0,18	1	10
220.35.40	2120/16 L	75	35	40	6	2020/06	0,18	1	10
220.30.50	2120/18 L	80	30	50	6	2020/06	0,19	1	10
220.35.45	2120/17 L	80	35	45	6	2020/06	0,19	1	10
220.40.40	2120/08 L	80	40	40	6	2020/06	0,19	1	10
220.30.55	2120/23 L	85	30	55	6	2020/06	0,20	1	10
220.35.50	2120/28 L	85	35	50	6	2020/06	0,20	1	10
220.40.45	2120/19 L	85	40	45	6	2020/06	0,20	1	10
220.30.60	2120/24 L	90	30	60	6	2020/06	0,21	1	5
220.35.55	2120/29 L	90	35	55	6	2020/06	0,21	1	5
220.40.50	2120/20 L	90	40	50	6	2020/06	0,21	1	5
220.45.45	2120/21 L	90	45	45	6	2020/06	0,21	1	5
220.30.65	2120/25 L	95	30	65	6	2020/06	0,22	1	5
220.35.60	2120/30 L	95	35	60	6	2020/06	0,22	1	5
220.40.55	2120/32 L	95	40	55	6	2020/06	0,22	1	5
220.45.50	2120/36 L	95	45	50	6	2020/06	0,22	1	5
220.30.70	2120/26 L	100	30	70	6	2020/06	0,23	1	5
220.35.65	2120/31 L	100	35	65	6	2020/06	0,23	1	5
220.40.60	2120/33 L	100	40	60	6	2020/06	0,23	1	5
220.45.55	2120/37 L	100	45	55	6	2020/06	0,23	1	5
220.50.50	2120/22 L	100	50	50	6	2020/06	0,23	1	5
220.30.75	2120/42 L	105	30	75	6	2020/06	0,24	1	5
220.45.60	2120/43 L	105	45	60	6	2020/06	0,24	1	5
220.30.80	2120/27 L	110	30	80	6	2020/06	0,25	1	5
220.40.70	2120/34 L	110	40	70	6	2020/06	0,25	1	5
220.45.65	2120/46 L	110	45	65	6	2020/06	0,25	1	5
220.50.60	2120/38 L	110	50	60	6	2020/06	0,25	1	5
220.55.55	2120/45 L	110	55	55	6	2020/06	0,25	1	5
220.50.65	2120/44 L	115	50	65	6	2020/06	0,26	1	5
220.30.90	2120/41 L	120	30	90	6	2020/06	0,27	1	5
220.40.80	2120/35 L	120	40	80	6	2020/06	0,27	1	5
220.50.70	2120/40 L	120	50	70	6	2020/06	0,27	1	5
220.60.60	2120/39 L	120	60	60	6	2020/06	0,27	1	5
220.**.**.N									Finitura Nera a richiesta
220.**.**.T									Finitura Ottone a richiesta

DOPPIO CILINDRO CON CHIAVE CANTIERE

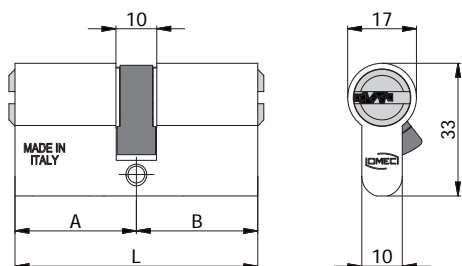

CARATTERISTICHE COSTRUTTIVE:

Corpo in alluminio ad alta resistenza - Barilotti in ottone nichelato con guida-chiave - Perni e controperni in acciaio inox - Molle in acciaio inox - Camma DIN disassata di 30° in acciaio autolubrificante - Chiavi proprietario piatte reversibili in alpaca con numero di codice - Chiave cantiere in ottone con numero di codice.

FUNZIONAMENTO:







Rotazione della chiave di 360° - Le chiavi sono dipendenti e non possono azionare il cilindro se dall'altro lato è stata inserita e ruotata la chiave.

PARTI IN DOTAZIONE:

3 chiavi, 1 chiave cantiere, carta di proprietà.

VARIANTI A RICHIESTA:

Impianti speciali KA-MK-GMK-CL.

COD.	EX COD.	L	A	B						
220.30.30.TK	2120/04 LTK	60	30	30	6	2020/06	0,19	1	10	
220.30.35.TK	2120/11 LTK	65	30	35	6	2020/06	0,19	1	10	
220.30.40.TK	2120/14 LTK	70	30	40	6	2020/06	0,20	1	10	
220.35.35.TK	2120/06 LTK	70	35	35	6	2020/06	0,20	1	10	
220.30.45.TK	2120/15 LTK	75	30	45	6	2020/06	0,21	1	10	
220.35.40.TK	2120/16 LTK	75	35	40	6	2020/06	0,21	1	10	
220.30.50.TK	2120/18 LTK	80	30	50	6	2020/06	0,22	1	10	
220.35.45.TK	2120/17 LTK	80	35	45	6	2020/06	0,22	1	10	
220.40.40.TK	2120/08 LTK	80	40	40	6	2020/06	0,22	1	10	
220.30.55.TK	2120/23 LTK	85	30	55	6	2020/06	0,23	1	10	
220.35.50.TK	2120/28 LTK	85	35	50	6	2020/06	0,23	1	10	
220.40.45.TK	2120/19 LTK	85	40	45	6	2020/06	0,23	1	10	
220.30.60.TK	2120/24 LTK	90	30	60	6	2020/06	0,24	1	5	
220.35.55.TK	2120/29 LTK	90	35	55	6	2020/06	0,24	1	5	
220.40.50.TK	2120/20 LTK	90	40	50	6	2020/06	0,24	1	5	
220.45.45.TK	2120/21 LTK	90	45	45	6	2020/06	0,24	1	5	
220.30.65.TK	2120/25 LTK	95	30	65	6	2020/06	0,25	1	5	
220.35.60.TK	2120/30 LTK	95	35	60	6	2020/06	0,25	1	5	
220.40.55.TK	2120/32 LTK	95	40	55	6	2020/06	0,25	1	5	
220.45.50.TK	2120/36 LTK	95	45	50	6	2020/06	0,25	1	5	
220.30.70.TK	2120/26 LTK	100	30	70	6	2020/06	0,26	1	5	
220.35.65.TK	2120/31 LTK	100	35	65	6	2020/06	0,26	1	5	
220.40.60.TK	2120/33 LTK	100	40	60	6	2020/06	0,26	1	5	
220.45.55.TK	2120/37 LTK	100	45	55	6	2020/06	0,26	1	5	
220.50.50.TK	2120/22 LTK	100	50	50	6	2020/06	0,26	1	5	
220.30.75.TK	2120/42 LTK	105	30	75	6	2020/06	0,27	1	5	
220.45.60.TK	2120/43 LTK	105	45	60	6	2020/06	0,27	1	5	
220.30.80.TK	2120/27 LTK	110	30	80	6	2020/06	0,28	1	5	
220.40.70.TK	2120/34 LTK	110	40	70	6	2020/06	0,28	1	5	
220.45.65.TK	2120/46 LTK	110	45	65	6	2020/06	0,28	1	5	
220.50.60.TK	2120/38 LTK	110	50	60	6	2020/06	0,28	1	5	
220.55.55.TK	2120/45 LTK	110	55	55	6	2020/06	0,28	1	5	
220.50.65.TK	2120/44 LTK	115	50	65	6	2020/06	0,29	1	5	
220.30.90.TK	2120/41 LTK	120	30	90	6	2020/06	0,30	1	5	
220.40.80.TK	2120/35 LTK	120	40	80	6	2020/06	0,30	1	5	
220.50.70.TK	2120/40 LTK	120	50	70	6	2020/06	0,30	1	5	
220.60.60.TK	2120/39 LTK	120	60	60	6	2020/06	0,30	1	5	
220.**.**.N.TK						Finitura Nera a richiesta				
220.**.**.T.TK						Finitura Ottone a richiesta				

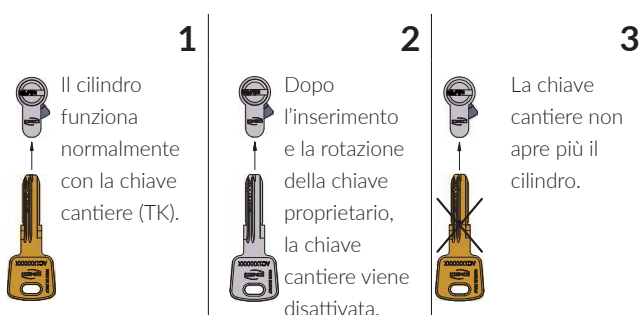

DOPPIO CILINDRO

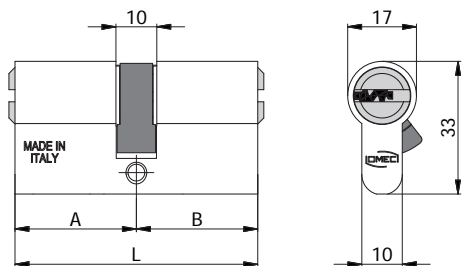

CARATTERISTICHE COSTRUTTIVE:

Corpo in alluminio ad alta resistenza - Barilotti in ottone nichelato con guida-chiave - Perni e controperni in acciaio inox - Molle in acciaio inox - Camma DIN disassata di 30° in acciaio autolubrificante - Chiavi piatte reversibili in alpacca con numero di codice.

FUNZIONAMENTO:





Rotazione della chiave di 360° - Le chiavi sono dipendenti e non possono azionare il cilindro se dall'altro lato é stata inserita e ruotata la chiave.

PARTI IN DOTAZIONE:

5 chiavi, carta di proprietà.

VARIANTI A RICHIESTA:

Impianti speciali KA-MK-GMK-CL.

COD.	EX COD.	L	A	B					
220.30.30.5	2120/504 L	60	30	30	6	2020/06	0,21	1	10
220.30.35.5	2120/511 L	65	30	35	6	2020/06	0,21	1	10
220.30.40.5	2120/514 L	70	30	40	6	2020/06	0,22	1	10
220.35.35.5	2120/506 L	70	35	35	6	2020/06	0,22	1	10
220.30.45.5	2120/515 L	75	30	45	6	2020/06	0,23	1	10
220.35.40.5	2120/516 L	75	35	40	6	2020/06	0,23	1	10
220.30.50.5	2120/518 L	80	30	50	6	2020/06	0,24	1	10
220.35.45.5	2120/517 L	80	35	45	6	2020/06	0,24	1	10
220.40.40.5	2120/508 L	80	40	40	6	2020/06	0,24	1	10
220.30.55.5	2120/523 L	85	30	55	6	2020/06	0,25	1	10
220.35.50.5	2120/528 L	85	35	50	6	2020/06	0,25	1	10
220.40.45.5	2120/519 L	85	40	45	6	2020/06	0,25	1	10
220.30.60.5	2120/524 L	90	30	60	6	2020/06	0,26	1	5
220.35.55.5	2120/529 L	90	35	55	6	2020/06	0,26	1	5
220.40.50.5	2120/520 L	90	40	50	6	2020/06	0,26	1	5
220.45.45.5	2120/521 L	90	45	45	6	2020/06	0,26	1	5
220.30.65.5	2120/525 L	95	30	65	6	2020/06	0,27	1	5
220.35.60.5	2120/530 L	95	35	60	6	2020/06	0,27	1	5
220.40.55.5	2120/532 L	95	40	55	6	2020/06	0,27	1	5
220.45.50.5	2120/536 L	95	45	50	6	2020/06	0,27	1	5
220.30.70.5	2120/526 L	100	30	70	6	2020/06	0,28	1	5
220.35.65.5	2120/531 L	100	35	65	6	2020/06	0,28	1	5
220.40.60.5	2120/533 L	100	40	60	6	2020/06	0,28	1	5
220.45.55.5	2120/537 L	100	45	55	6	2020/06	0,28	1	5
220.50.50.5	2120/522 L	100	50	50	6	2020/06	0,28	1	5
220.30.75.5	2120/542 L	105	30	75	6	2020/06	0,29	1	5
220.45.60.5	2120/543 L	105	45	60	6	2020/06	0,29	1	5
220.30.80.5	2120/527 L	110	30	80	6	2020/06	0,30	1	5
220.40.70.5	2120/534 L	110	40	70	6	2020/06	0,30	1	5
220.45.65.5	2120/546 L	110	45	65	6	2020/06	0,30	1	5
220.50.60.5	2120/538 L	110	50	60	6	2020/06	0,30	1	5
220.55.55.5	2120/545 L	110	55	55	6	2020/06	0,30	1	5
220.50.65.5	2120/544 L	115	50	65	6	2020/06	0,31	1	5
220.30.90.5	2120/541 L	120	30	90	6	2020/06	0,32	1	5
220.40.80.5	2120/535 L	120	40	80	6	2020/06	0,32	1	5
220.50.70.5	2120/540 L	120	50	70	6	2020/06	0,32	1	5
220.60.60.5	2120/539 L	120	60	60	6	2020/06	0,32	1	5
220.**.**.N.5						Finitura Nera a richiesta			
220.**.**.T.5						Finitura Ottone a richiesta			

DOPPIO CILINDRO CON CHIAVE CANTIERE

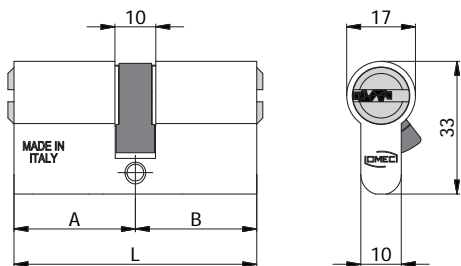

CARATTERISTICHE COSTRUTTIVE:

Corpo in alluminio ad alta resistenza - Barilotti in ottone nichelato con guida-chiave - Perni e controperni in acciaio inox - Molle in acciaio inox - Camma DIN disassata di 30° in acciaio autolubrificante - Chiavi proprietario piatte reversibili in alpaca con numero di codice - Chiave cantiere in ottone con numero di codice.

FUNZIONAMENTO:





Rotazione della chiave di 360° - Le chiavi sono dipendenti e non possono azionare il cilindro se dall'altro lato è stata inserita e ruotata la chiave.

PARTI IN DOTAZIONE:

5 chiavi, 1 chiave cantiere, carta di proprietà.

VARIANTI A RICHIESTA:

Impianti speciali KA-MK-GMK-CL.

COD.	EX COD.	L	A	B					
220.30.30.5.TK	2120/504 L TK	60	30	30	6	2020/06	0,23	1	5
220.30.35.5.TK	2120/511 L TK	65	30	35	6	2020/06	0,23	1	5
220.30.40.5.TK	2120/514 L TK	70	30	40	6	2020/06	0,24	1	5
220.35.35.5.TK	2120/506 L TK	70	35	35	6	2020/06	0,24	1	5
220.30.45.5.TK	2120/515 L TK	75	30	45	6	2020/06	0,25	1	5
220.35.40.5.TK	2120/516 L TK	75	35	40	6	2020/06	0,25	1	5
220.30.50.5.TK	2120/518 L TK	80	30	50	6	2020/06	0,26	1	5
220.35.45.5.TK	2120/517 L TK	80	35	45	6	2020/06	0,26	1	5
220.40.40.5.TK	2120/508 L TK	80	40	40	6	2020/06	0,26	1	5
220.30.55.5.TK	2120/523 L TK	85	30	55	6	2020/06	0,27	1	5
220.35.50.5.TK	2120/528 L TK	85	35	50	6	2020/06	0,27	1	5
220.40.45.5.TK	2120/519 L TK	85	40	45	6	2020/06	0,27	1	5
220.30.60.5.TK	2120/524 L TK	90	30	60	6	2020/06	0,28	1	5
220.35.55.5.TK	2120/529 L TK	90	35	55	6	2020/06	0,28	1	5
220.40.50.5.TK	2120/520 L TK	90	40	50	6	2020/06	0,28	1	5
220.45.45.5.TK	2120/521 L TK	90	45	45	6	2020/06	0,28	1	5
220.30.65.5.TK	2120/525 L TK	95	30	65	6	2020/06	0,29	1	5
220.35.60.5.TK	2120/530 L TK	95	35	60	6	2020/06	0,29	1	5
220.40.55.5.TK	2120/532 L TK	95	40	55	6	2020/06	0,29	1	5
220.45.50.5.TK	2120/536 L TK	95	45	50	6	2020/06	0,29	1	5
220.30.70.5.TK	2120/526 L TK	100	30	70	6	2020/06	0,30	1	5
220.35.65.5.TK	2120/531 L TK	100	35	65	6	2020/06	0,30	1	5
220.40.60.5.TK	2120/533 L TK	100	40	60	6	2020/06	0,30	1	5
220.45.55.5.TK	2120/537 L TK	100	45	55	6	2020/06	0,30	1	5
220.50.50.5.TK	2120/522 L TK	100	50	50	6	2020/06	0,30	1	5
220.30.75.5.TK	2120/542 L TK	105	30	75	6	2020/06	0,31	1	5
220.45.60.5.TK	2120/543 L TK	105	45	60	6	2020/06	0,31	1	5
220.30.80.5.TK	2120/527 L TK	110	30	80	6	2020/06	0,32	1	5
220.40.70.5.TK	2120/534 L TK	110	40	70	6	2020/06	0,32	1	5
220.45.65.5.TK	2120/546 L TK	110	45	65	6	2020/06	0,32	1	5
220.50.60.5.TK	2120/538 L TK	110	50	60	6	2020/06	0,32	1	5
220.55.55.5.TK	2120/545 L TK	110	55	55	6	2020/06	0,32	1	5
220.50.65.5.TK	2120/544 L TK	115	50	65	6	2020/06	0,33	1	5
220.30.90.5.TK	2120/541 L TK	120	30	90	6	2020/06	0,34	1	5
220.40.80.5.TK	2120/535 L TK	120	40	80	6	2020/06	0,34	1	5
220.50.70.5.TK	2120/540 L TK	120	50	70	6	2020/06	0,34	1	5
220.60.60.5.TK	2120/539 L TK	120	60	60	6	2020/06	0,34	1	5
220.**.**.N.5.TK						Finitura Nera a richiesta			
220.**.**.T.5.TK						Finitura Ottone a richiesta			

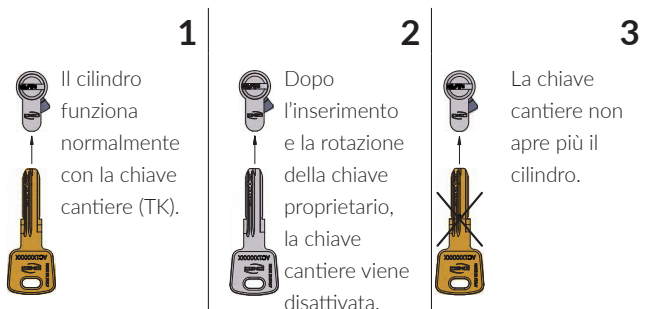

MEZZO CILINDRO



CARATTERISTICHE COSTRUTTIVE:

Corpo in alluminio ad alta resistenza - Barilotto in ottone nichelato con guida-chiave - Perni e contoperni in acciaio inox - Molle in acciaio inox - Camma DIN disassata di 30° in acciaio autolubrificante - Chiavi piatte reversibili in alpacca con numero di codice.

FUNZIONAMENTO:

Rotazione della chiave di 360°.



PARTI IN DOTAZIONE:

3 chiavi.

VARIANTI A RICHIESTA:

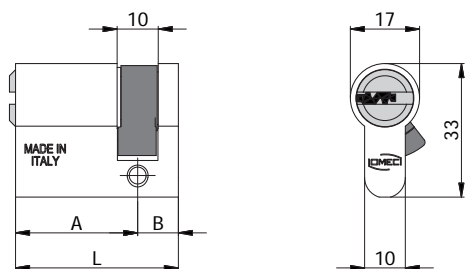
Impianti speciali KA-MK-GMK-CL.



COD.	EX COD.	L	A	B					
221.27.10	2121/03 L	37	27	10	5	2020/06	0,10	1	10
221.30.10	2121/04 L	40	30	10	6	2020/06	0,11	1	10
221.35.10	2121/06 L	45	35	10	6	2020/06	0,12	1	10
221.40.10	2121/08 L	50	40	10	6	2020/06	0,13	1	10
221.45.10	2121/15 L	55	45	10	6	2020/06	0,15	1	10
221.50.10	2121/18 L	60	50	10	6	2020/06	0,16	1	10
221.55.10	2121/23 L	65	55	10	6	2020/06	0,17	1	10
221.60.10	2121/24 L	70	60	10	6	2020/06	0,18	1	10
221.65.10	2121/25 L	75	65	10	6	2020/06	0,19	1	10
221.70.10	2121/26 L	80	70	10	6	2020/06	0,20	1	10
221.80.10	2121/27 L	90	80	10	6	2020/06	0,22	1	5
221.**.10.N									Finitura Nera a richiesta
221.**.10.T									Finitura Ottone a richiesta

MEZZO CILINDRO CON CHIAVE CANTIERE



CARATTERISTICHE COSTRUTTIVE:

Corpo in alluminio ad alta resistenza - Barilotto in ottone nichelato con guida-chiave - Perni e contoperni in acciaio inox - Molle in acciaio inox - Camma DIN dissassata di 30° in acciaio autolubrificante - Chiavi proprietario piatte reversibili in alpacca con numero di codice - Chiave cantiere in ottone con numero di codice.

FUNZIONAMENTO:

Rotazione della chiave di 360°.





PARTI IN DOTAZIONE:

3 chiavi, 1 chiave cantiere, carta di proprietà.

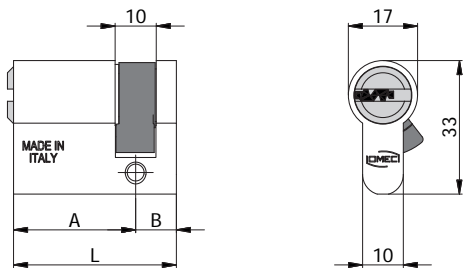
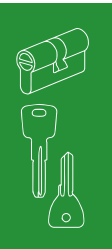
VARIANTI A RICHIESTA:

Impianti speciali KA-MK-GMK-CL.



COD.	EX COD.	L	A	B					
221.27.10.TK	2121/03 L TK	37	27	10	5	2020/06	0,13	1	10
221.30.10.TK	2121/04 L TK	40	30	10	6	2020/06	0,14	1	10
221.35.10.TK	2121/06 L TK	45	35	10	6	2020/06	0,15	1	10
221.40.10.TK	2121/08 L TK	50	40	10	6	2020/06	0,16	1	10
221.45.10.TK	2121/15 L TK	55	45	10	6	2020/06	0,18	1	10
221.50.10.TK	2121/18 L TK	60	50	10	6	2020/06	0,19	1	10
221.55.10.TK	2121/23 L TK	65	55	10	6	2020/06	0,20	1	10
221.60.10.TK	2121/24 L TK	70	60	10	6	2020/06	0,21	1	10
221.65.10.TK	2121/25 L TK	75	65	10	6	2020/06	0,22	1	10
221.70.10.TK	2121/26 L TK	80	70	10	6	2020/06	0,23	1	10
221.80.10.TK	2121/27 L TK	90	80	10	6	2020/06	0,25	1	5
221.**.10.N.TK		Finitura Nera a richiesta							
221.**.10.T.TK		Finitura Ottone a richiesta							

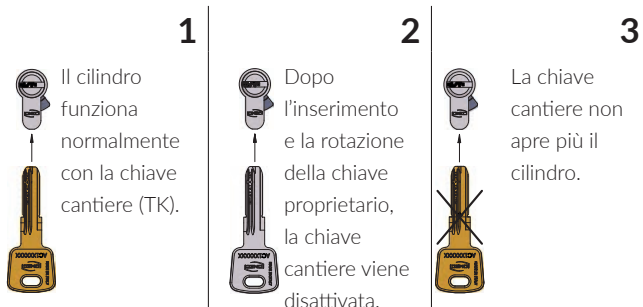

MEZZO CILINDRO



CARATTERISTICHE COSTRUTTIVE:

Corpo in alluminio ad alta resistenza - Barilotto in ottone nichelato con guida-chiave - Perni e contoperni in acciaio inox - Molle in acciaio inox - Camma DIN disassata di 30° in acciaio autolubrificante - Chiavi piatte reversibili in alpaca con numero di codice.

FUNZIONAMENTO:

Rotazione della chiave di 360°.





PARTI IN DOTAZIONE:

5 chiavi, carta di proprietà.

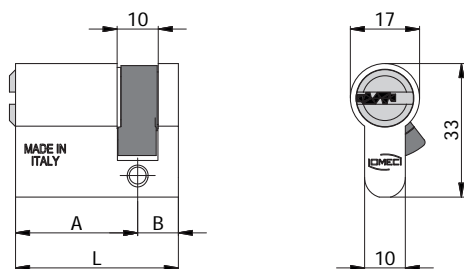
VARIANTI A RICHIESTA:

Impianti speciali KA-MK-GMK-CL.



COD.	EX COD.	L	A	B					
221.27.10.5	2121/503 L	37	27	10	5	2020/06	0,15	1	10
221.30.10.5	2121/504 L	40	30	10	6	2020/06	0,16	1	10
221.35.10.5	2121/506 L	45	35	10	6	2020/06	0,17	1	10
221.40.10.5	2121/508 L	50	40	10	6	2020/06	0,18	1	10
221.45.10.5	2121/515 L	55	45	10	6	2020/06	0,20	1	10
221.50.10.5	2121/518 L	60	50	10	6	2020/06	0,21	1	10
221.55.10.5	2121/523 L	65	55	10	6	2020/06	0,22	1	10
221.60.10.5	2121/524 L	70	60	10	6	2020/06	0,23	1	10
221.65.10.5	2121/525 L	75	65	10	6	2020/06	0,24	1	10
221.70.10.5	2121/526 L	80	70	10	6	2020/06	0,25	1	10
221.80.10.5	2121/527 L	90	80	10	6	2020/06	0,27	1	5
221.**.10.N.5		Finitura Nera a richiesta							
221.**.10.T.5		Finitura Ottone a richiesta							

MEZZO CILINDRO CON CHIAVE CANTIERE



CARATTERISTICHE COSTRUTTIVE:

Corpo in alluminio ad alta resistenza - Barilotto in ottone nichelato con guida-chiave - Perni e contoperni in acciaio inox - Molle in acciaio inox - Camma DIN dissata di 30° in acciaio autolubrificante - Chiavi proprietario piatte reversibili in alpacca con numero di codice - Chiave cantiere in ottone con numero di codice.

FUNZIONAMENTO:

Rotazione della chiave di 360°.



PARTI IN DOTAZIONE:

5 chiavi, 1 chiave cantiere, carta di proprietà.

VARIANTI A RICHIESTA:

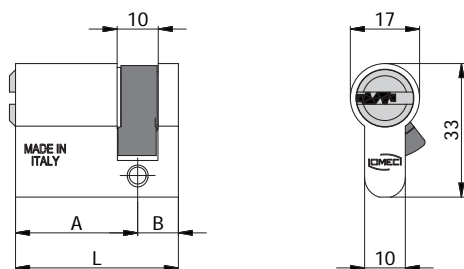
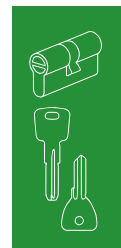
Impianti speciali KA-MK-GMK-CL.



COD.	EX COD.	L	A	B					
221.27.10.5.TK	2121/503 L TK	37	27	10	5	2020/06	0,17	1	10
221.30.10.5.TK	2121/504 L TK	40	30	10	6	2020/06	0,18	1	10
221.35.10.5.TK	2121/506 L TK	45	35	10	6	2020/06	0,19	1	10
221.40.10.5.TK	2121/508 L TK	50	40	10	6	2020/06	0,20	1	10
221.45.10.5.TK	2121/515 L TK	55	45	10	6	2020/06	0,22	1	10
221.50.10.5.TK	2121/518 L TK	60	50	10	6	2020/06	0,23	1	10
221.55.10.5.TK	2121/523 L TK	65	55	10	6	2020/06	0,24	1	10
221.60.10.5.TK	2121/524 L TK	70	60	10	6	2020/06	0,25	1	10
221.65.10.5.TK	2121/525 L TK	75	65	10	6	2020/06	0,26	1	10
221.70.10.5.TK	2121/526 L TK	80	70	10	6	2020/06	0,27	1	10
221.80.10.5.TK	2121/527 L TK	90	80	10	6	2020/06	0,29	1	5
221.**.10.N.5.TK		Finitura Nera a richiesta							
221.**.10.T.5.TK		Finitura Ottone a richiesta							

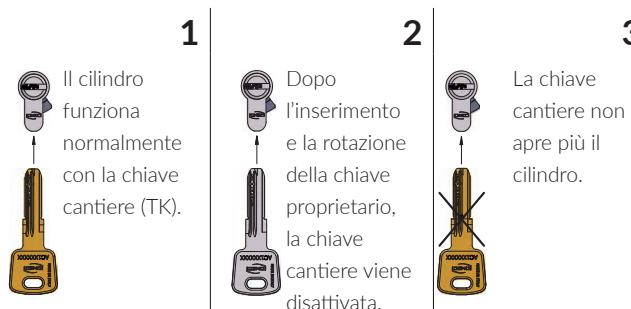

DOPPIO CILINDRO FRIZIONATO

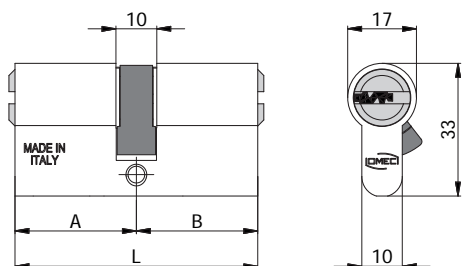
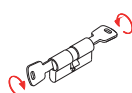

CARATTERISTICHE COSTRUTTIVE:

Corpo in alluminio ad alta resistenza - Barilotti in ottone nichelato con guida-chiave - Perni e controperni in acciaio inox - Molle in acciaio inox - Camma DIN disassata di 30° in acciaio autolubrificante - Chiavi piatte reversibili in alpacca con numero di codice.

FUNZIONAMENTO:



Rotazione della chiave di 360° - Le chiavi sono indipendenti e possono azionare il cilindro anche se dall'altro lato é stata inserita e ruotata la chiave.

PARTI IN DOTAZIONE:

3 chiavi.

VARIANTI A RICHIESTA:

Impianti speciali KA-MK-GMK-CL.

COD.	EX COD.	L	A	B					
222.30.30	2122/04 L	60	30	30	6	2020/06	0,16	1	10
222.30.35	2122/11 L	65	30	35	6	2020/06	0,16	1	10
222.30.40	2122/14 L	70	30	40	6	2020/06	0,17	1	10
222.35.35	2122/06 L	70	35	35	6	2020/06	0,17	1	10
222.30.45	2122/15 L	75	30	45	6	2020/06	0,18	1	10
222.35.40	2122/16 L	75	35	40	6	2020/06	0,18	1	10
222.30.50	2122/18 L	80	30	50	6	2020/06	0,19	1	10
222.35.45	2122/17 L	80	35	45	6	2020/06	0,19	1	10
222.40.40	2122/08 L	80	40	40	6	2020/06	0,19	1	10
222.30.55	2122/23 L	85	30	55	6	2020/06	0,20	1	10
222.35.50	2122/28 L	85	35	50	6	2020/06	0,20	1	10
222.40.45	2122/19 L	85	40	45	6	2020/06	0,20	1	10
222.30.60	2122/24 L	90	30	60	6	2020/06	0,21	1	5
222.35.55	2122/29 L	90	35	55	6	2020/06	0,21	1	5
222.40.50	2122/20 L	90	40	50	6	2020/06	0,21	1	5
222.45.45	2122/21 L	90	45	45	6	2020/06	0,21	1	5
222.30.65	2122/25 L	95	30	65	6	2020/06	0,22	1	5
222.35.60	2122/30 L	95	35	60	6	2020/06	0,22	1	5
222.40.55	2122/32 L	95	40	55	6	2020/06	0,22	1	5
222.45.50	2122/36 L	95	45	50	6	2020/06	0,22	1	5
222.30.70	2122/26 L	100	30	70	6	2020/06	0,23	1	5
222.35.65	2122/31 L	100	35	65	6	2020/06	0,23	1	5
222.40.60	2122/33 L	100	40	60	6	2020/06	0,23	1	5
222.45.55	2122/37 L	100	45	55	6	2020/06	0,23	1	5
222.50.50	2122/22 L	100	50	50	6	2020/06	0,23	1	5
222.30.75	2122/42 L	105	30	75	6	2020/06	0,24	1	5
222.45.60	2122/43 L	105	45	60	6	2020/06	0,24	1	5
222.30.80	2122/27 L	110	30	80	6	2020/06	0,25	1	5
222.40.70	2122/34 L	110	40	70	6	2020/06	0,25	1	5
222.45.65	2122/46 L	110	45	65	6	2020/06	0,25	1	5
222.50.60	2122/38 L	110	50	60	6	2020/06	0,25	1	5
222.55.55	2122/45 L	110	55	55	6	2020/06	0,25	1	5
222.50.65	2122/44 L	115	50	65	6	2020/06	0,26	1	5
222.30.90	2122/41 L	120	30	90	6	2020/06	0,27	1	5
222.40.80	2122/35 L	120	40	80	6	2020/06	0,27	1	5
222.50.70	2122/40 L	120	50	70	6	2020/06	0,27	1	5
222.60.60	2122/39 L	120	60	60	6	2020/06	0,27	1	5
222.**.**.N									Finitura Nera a richiesta
222.**.**.T									Finitura Ottone a richiesta

DOPPIO CILINDRO FRIZIONATO CON CHIAVE CANTIERE

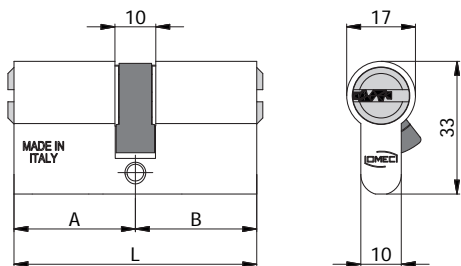
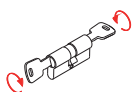

CARATTERISTICHE COSTRUTTIVE:

Corpo in alluminio ad alta resistenza - Barilotti in ottone nichelato con guida-chiave - Perni e controperni in acciaio inox - Molle in acciaio inox - Camma DIN disassata di 30° in acciaio autolubrificante - Chiavi proprietario piatte reversibili in alpaca con numero di codice - Chiave cantiere in ottone con numero di codice.

FUNZIONAMENTO:

Rotazione della chiave di 360° - Le chiavi sono indipendenti e possono azionare il cilindro anche se dall'altro lato é stata inserita e ruotata la chiave.

PARTI IN DOTAZIONE:

3 chiavi, 1 chiave cantiere, carta di proprietà.

VARIANTI A RICHIESTA:

Impianti speciali KA-MK-GMK-CL.

COD.	EX COD.	L	A	B					
222.30.30.TK	2122/04 LTK	60	30	30	6	2020/06	0,19	1	10
222.30.35.TK	2122/11 LTK	65	30	35	6	2020/06	0,19	1	10
222.30.40.TK	2122/14 LTK	70	30	40	6	2020/06	0,20	1	10
222.35.35.TK	2122/06 LTK	70	35	35	6	2020/06	0,20	1	10
222.30.45.TK	2122/15 LTK	75	30	45	6	2020/06	0,21	1	10
222.35.40.TK	2122/16 LTK	75	35	40	6	2020/06	0,21	1	10
222.30.50.TK	2122/18 LTK	80	30	50	6	2020/06	0,22	1	10
222.35.45.TK	2122/17 LTK	80	35	45	6	2020/06	0,22	1	10
222.40.40.TK	2122/08 LTK	80	40	40	6	2020/06	0,22	1	10
222.30.55.TK	2122/23 LTK	85	30	55	6	2020/06	0,23	1	10
222.35.50.TK	2122/28 LTK	85	35	50	6	2020/06	0,23	1	10
222.40.45.TK	2122/19 LTK	85	40	45	6	2020/06	0,23	1	10
222.30.60.TK	2122/24 LTK	90	30	60	6	2020/06	0,24	1	5
222.35.55.TK	2122/29 LTK	90	35	55	6	2020/06	0,24	1	5
222.40.50.TK	2122/20 LTK	90	40	50	6	2020/06	0,24	1	5
222.45.45.TK	2122/21 LTK	90	45	45	6	2020/06	0,24	1	5
222.30.65.TK	2122/25 LTK	95	30	65	6	2020/06	0,25	1	5
222.35.60.TK	2122/30 LTK	95	35	60	6	2020/06	0,25	1	5
222.40.55.TK	2122/32 LTK	95	40	55	6	2020/06	0,25	1	5
222.45.50.TK	2122/36 LTK	95	45	50	6	2020/06	0,25	1	5
222.30.70.TK	2122/26 LTK	100	30	70	6	2020/06	0,26	1	5
222.35.65.TK	2122/31 LTK	100	35	65	6	2020/06	0,26	1	5
222.40.60.TK	2122/33 LTK	100	40	60	6	2020/06	0,26	1	5
222.45.55.TK	2122/37 LTK	100	45	55	6	2020/06	0,26	1	5
222.50.50.TK	2122/22 LTK	100	50	50	6	2020/06	0,26	1	5
222.30.75.TK	2122/42 LTK	105	30	75	6	2020/06	0,27	1	5
222.45.60.TK	2122/43 LTK	105	45	60	6	2020/06	0,27	1	5
222.30.80.TK	2122/27 LTK	110	30	80	6	2020/06	0,28	1	5
222.40.70.TK	2122/34 LTK	110	40	70	6	2020/06	0,28	1	5
222.45.65.TK	2122/46 LTK	110	45	65	6	2020/06	0,28	1	5
222.50.60.TK	2122/38 LTK	110	50	60	6	2020/06	0,28	1	5
222.55.55.TK	2122/45 LTK	110	55	55	6	2020/06	0,28	1	5
222.50.65.TK	2122/44 LTK	115	50	65	6	2020/06	0,29	1	5
222.30.90.TK	2122/41 LTK	120	30	90	6	2020/06	0,30	1	5
222.40.80.TK	2122/35 LTK	120	40	80	6	2020/06	0,30	1	5
222.50.70.TK	2122/40 LTK	120	50	70	6	2020/06	0,30	1	5
222.60.60.TK	2122/39 LTK	120	60	60	6	2020/06	0,30	1	5
222.**.**.N.TK						Finitura Nera a richiesta			
222.**.**.T.TK						Finitura Ottone a richiesta			

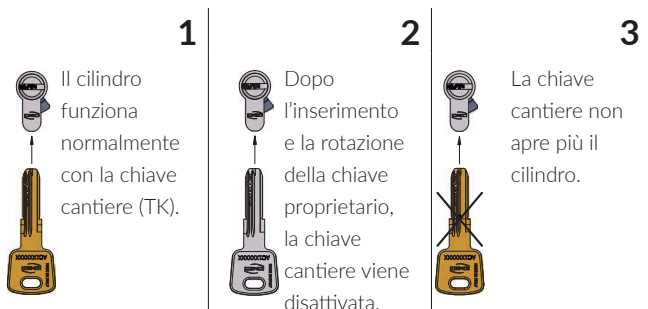

DOPPIO CILINDRO FRIZIONATO

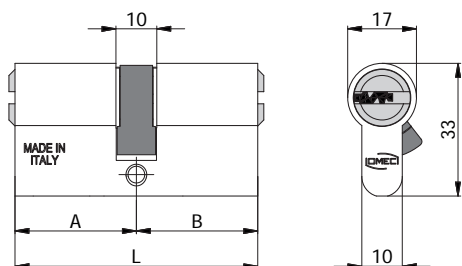

CARATTERISTICHE COSTRUTTIVE:

Corpo in alluminio ad alta resistenza - Barilotti in ottone nichelato con guida-chiave - Perni e contoperni in acciaio inox - Molle in acciaio inox - Camma DIN disassata di 30° in acciaio autolubrificante - Chiavi piatte reversibili in alpacca con numero di codice.

FUNZIONAMENTO:





Rotazione della chiave di 360° - Le chiavi sono indipendenti e possono azionare il cilindro anche se dall'altro lato é stata inserita e ruotata la chiave.

PARTI IN DOTAZIONE:

5 chiavi, carta di proprietà.





VARIANTI A RICHIESTA:

Impianti speciali KA-MK-GMK-CL.

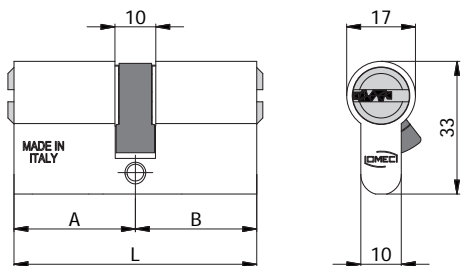
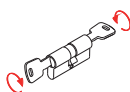
COD.	EX COD.	L	A	B					
222.30.30.5	2122/504 L	60	30	30	6	2020/06	0,21	1	10
222.30.35.5	2122/511 L	65	30	35	6	2020/06	0,21	1	10
222.30.40.5	2122/514 L	70	30	40	6	2020/06	0,22	1	10
222.35.35.5	2122/506 L	70	35	35	6	2020/06	0,22	1	10
222.30.45.5	2122/515 L	75	30	45	6	2020/06	0,23	1	10
222.35.40.5	2122/516 L	75	35	40	6	2020/06	0,23	1	10
222.30.50.5	2122/518 L	80	30	50	6	2020/06	0,24	1	10
222.35.45.5	2122/517 L	80	35	45	6	2020/06	0,24	1	10
222.40.40.5	2122/508 L	80	40	40	6	2020/06	0,24	1	10
222.30.55.5	2122/523 L	85	30	55	6	2020/06	0,25	1	10
222.35.50.5	2122/528 L	85	35	50	6	2020/06	0,25	1	10
222.40.45.5	2122/519 L	85	40	45	6	2020/06	0,25	1	10
222.30.60.5	2122/524 L	90	30	60	6	2020/06	0,26	1	5
222.35.55.5	2122/529 L	90	35	55	6	2020/06	0,26	1	5
222.40.50.5	2122/520 L	90	40	50	6	2020/06	0,26	1	5
222.45.45.5	2122/521 L	90	45	45	6	2020/06	0,26	1	5
222.30.65.5	2122/525 L	95	30	65	6	2020/06	0,27	1	5
222.35.60.5	2122/530 L	95	35	60	6	2020/06	0,27	1	5
222.40.55.5	2122/532 L	95	40	55	6	2020/06	0,27	1	5
222.45.50.5	2122/536 L	95	45	50	6	2020/06	0,27	1	5
222.30.70.5	2122/526 L	100	30	70	6	2020/06	0,28	1	5
222.35.65.5	2122/531 L	100	35	65	6	2020/06	0,28	1	5
222.40.60.5	2122/533 L	100	40	60	6	2020/06	0,28	1	5
222.45.55.5	2122/537 L	100	45	55	6	2020/06	0,28	1	5
222.50.50.5	2122/522 L	100	50	50	6	2020/06	0,28	1	5
222.30.75.5	2122/542 L	105	30	75	6	2020/06	0,29	1	5
222.45.60.5	2122/543 L	105	45	60	6	2020/06	0,29	1	5
222.30.80.5	2122/527 L	110	30	80	6	2020/06	0,30	1	5
222.40.70.5	2122/534 L	110	40	70	6	2020/06	0,30	1	5
222.45.65.5	2122/546 L	110	45	65	6	2020/06	0,30	1	5
222.50.60.5	2122/538 L	110	50	60	6	2020/06	0,30	1	5
222.55.55.5	2122/545 L	110	55	55	6	2020/06	0,30	1	5
222.50.65.5	2122/544 L	115	50	65	6	2020/06	0,31	1	5
222.30.90.5	2122/541 L	120	30	90	6	2020/06	0,32	1	5
222.40.80.5	2122/535 L	120	40	80	6	2020/06	0,32	1	5
222.50.70.5	2122/540 L	120	50	70	6	2020/06	0,32	1	5
222.60.60.5	2122/539 L	120	60	60	6	2020/06	0,32	1	5
222.**.**.N.5									Finitura Nera a richiesta
222.**.**.T.5									Finitura Ottone a richiesta

DOPPIO CILINDRO FRIZIONATO CON CHIAVE CANTIERE



COD.	EX COD.	L	A	B					
222.30.30.5.TK	2122/504 L TK	60	30	30	6	2020/06	0,23	1	5
222.30.35.5.TK	2122/511 L TK	65	30	35	6	2020/06	0,23	1	5
222.30.40.5.TK	2122/514 L TK	70	30	40	6	2020/06	0,24	1	5
222.35.35.5.TK	2122/506 L TK	70	35	35	6	2020/06	0,24	1	5
222.30.45.5.TK	2122/515 L TK	75	30	45	6	2020/06	0,25	1	5
222.35.40.5.TK	2122/516 L TK	75	35	40	6	2020/06	0,25	1	5
222.30.50.5.TK	2122/518 L TK	80	30	50	6	2020/06	0,26	1	5
222.35.45.5.TK	2122/517 L TK	80	35	45	6	2020/06	0,26	1	5
222.40.40.5.TK	2122/508 L TK	80	40	40	6	2020/06	0,26	1	5
222.30.55.5.TK	2122/523 L TK	85	30	55	6	2020/06	0,27	1	5
222.35.50.5.TK	2122/528 L TK	85	35	50	6	2020/06	0,27	1	5
222.40.45.5.TK	2122/519 L TK	85	40	45	6	2020/06	0,27	1	5
222.30.60.5.TK	2122/524 L TK	90	30	60	6	2020/06	0,28	1	5
222.35.55.5.TK	2122/529 L TK	90	35	55	6	2020/06	0,28	1	5
222.40.50.5.TK	2122/520 L TK	90	40	50	6	2020/06	0,28	1	5
222.45.45.5.TK	2122/521 L TK	90	45	45	6	2020/06	0,28	1	5
222.30.65.5.TK	2122/525 L TK	95	30	65	6	2020/06	0,29	1	5
222.35.60.5.TK	2122/530 L TK	95	35	60	6	2020/06	0,29	1	5
222.40.55.5.TK	2122/532 L TK	95	40	55	6	2020/06	0,29	1	5
222.45.50.5.TK	2122/536 L TK	95	45	50	6	2020/06	0,29	1	5
222.30.70.5.TK	2122/526 L TK	100	30	70	6	2020/06	0,30	1	5
222.35.65.5.TK	2122/531 L TK	100	35	65	6	2020/06	0,30	1	5
222.40.60.5.TK	2122/533 L TK	100	40	60	6	2020/06	0,30	1	5
222.45.55.5.TK	2122/537 L TK	100	45	55	6	2020/06	0,30	1	5
222.50.50.5.TK	2122/522 L TK	100	50	50	6	2020/06	0,30	1	5
222.30.75.5.TK	2122/542 L TK	105	30	75	6	2020/06	0,31	1	5
222.45.60.5.TK	2122/543 L TK	105	45	60	6	2020/06	0,31	1	5
222.30.80.5.TK	2122/527 L TK	110	30	80	6	2020/06	0,32	1	5
222.40.70.5.TK	2122/534 L TK	110	40	70	6	2020/06	0,32	1	5
222.45.65.5.TK	2122/546 L TK	110	45	65	6	2020/06	0,32	1	5
222.50.60.5.TK	2122/538 L TK	110	50	60	6	2020/06	0,32	1	5
222.55.55.5.TK	2122/545 L TK	110	55	55	6	2020/06	0,32	1	5
222.50.65.5.TK	2122/544 L TK	115	50	65	6	2020/06	0,33	1	5
222.30.90.5.TK	2122/541 L TK	120	30	90	6	2020/06	0,34	1	5
222.40.80.5.TK	2122/535 L TK	120	40	80	6	2020/06	0,34	1	5
222.50.70.5.TK	2122/540 L TK	120	50	70	6	2020/06	0,34	1	5
222.60.60.5.TK	2122/539 L TK	120	60	60	6	2020/06	0,34	1	5
222.**.**.N.5.TK									Finitura Nera a richiesta
222.**.**.T.5.TK									Finitura Ottone a richiesta

CARATTERISTICHE COSTRUTTIVE:

Corpo in alluminio ad alta resistenza - Barilotti in ottone nichelato con guida-chiave - Perni e controperni in acciaio inox - Molle in acciaio inox - Camma DIN disassata di 30° in acciaio autolubrificante - Chiavi proprietario piatte reversibili in alpaca con numero di codice - Chiave cantiere in ottone con numero di codice.

FUNZIONAMENTO:

Rotazione della chiave di 360° - Le chiavi sono indipendenti e possono azionare il cilindro anche se dall'altro lato é stata inserita e ruotata la chiave.

PARTI IN DOTAZIONE:

5 chiavi, 1 chiave cantiere, carta di proprietà.

VARIANTI A RICHIESTA:

Impianti speciali KA-MK-GMK-CL.

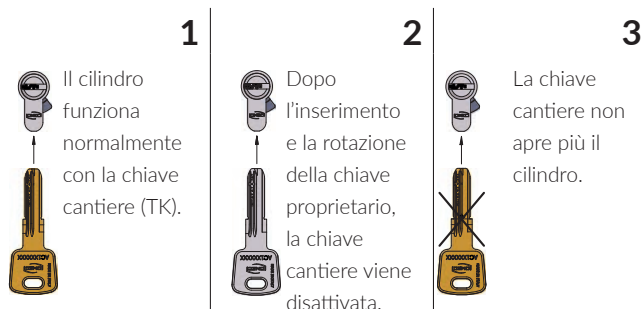

DOPPIO CILINDRO CON POMOLO

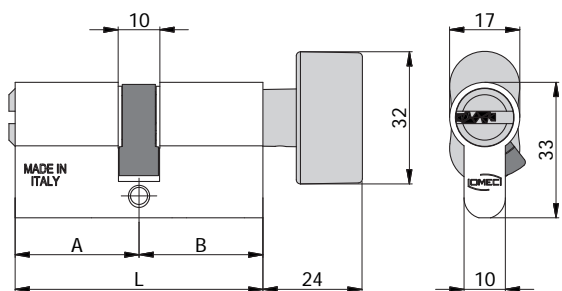

CARATTERISTICHE COSTRUTTIVE:

Corpo in alluminio ad alta resistenza - Barilotto in ottone nichelato con guida-chiave - Perni e controperni in acciaio inox - Molle in acciaio inox - Camma DIN disassata di 30° in acciaio autolubrificante - Pomolo in lega speciale cromo satinata - Chiavi piatte reversibili in alpacca con numero di codice.

FUNZIONAMENTO:

Rotazione della chiave o del pomolo di 360°.

PARTI IN DOTAZIONE:

3 chiavi.

VARIANTI A RICHIESTA:

Impianti speciali KA-MK-GMK-CL.

COD.	EX COD.	L	A	B					
223.30.30B	2123/04 L	60	30	30	6	2020/06	0,21	1	10
223.30.35B	2123/13 L	65	30	35	6	2020/06	0,21	1	5
223.35.30B	2123/20 L	65	35	30	6	2020/06	0,21	1	5
223.30.40B	2123/14 L	70	30	40	6	2020/06	0,22	1	5
223.35.35B	2123/07 L	70	35	35	6	2020/06	0,22	1	5
223.40.30B	2123/24 L	70	40	30	6	2020/06	0,22	1	5
223.30.45B	2123/15 L	75	30	45	6	2020/06	0,23	1	5
223.35.40B	2123/21 L	75	35	40	6	2020/06	0,23	1	5
223.40.35B	2123/25 L	75	40	35	6	2020/06	0,23	1	5
223.45.30B	2123/31 L	75	45	30	6	2020/06	0,23	1	5
223.30.50B	2123/16 L	80	30	50	6	2020/06	0,24	1	5
223.35.45B	2123/22 L	80	35	45	6	2020/06	0,24	1	5
223.40.40B	2123/10 L	80	40	40	6	2020/06	0,24	1	5
223.45.35B	2123/32 L	80	45	35	6	2020/06	0,24	1	5
223.50.30B	2123/35 L	80	50	30	6	2020/06	0,24	1	5
223.35.50B	2123/23 L	85	35	50	6	2020/06	0,25	1	5
223.40.45B	2123/26 L	85	40	45	6	2020/06	0,25	1	5
223.45.40B	2123/33 L	85	45	40	6	2020/06	0,25	1	5
223.50.35B	2123/36 L	85	50	35	6	2020/06	0,25	1	5
223.55.30B	2123/46 L	85	55	30	6	2020/06	0,25	1	5
223.30.60B	2123/17 L	90	30	60	6	2020/06	0,26	1	5
223.40.50B	2123/27 L	90	40	50	6	2020/06	0,26	1	5
223.45.45B	2123/34 L	90	45	45	6	2020/06	0,26	1	5
223.50.40B	2123/37 L	90	50	40	6	2020/06	0,26	1	5
223.60.30B	2123/40 L	90	60	30	6	2020/06	0,26	1	5
223.60.35B	2123/41 L	95	60	35	6	2020/06	0,27	1	5
223.30.70B	2123/18 L	100	30	70	6	2020/06	0,28	1	5
223.40.60B	2123/28 L	100	40	60	6	2020/06	0,28	1	5
223.50.50B	2123/38 L	100	50	50	6	2020/06	0,28	1	5
223.60.40B	2123/42 L	100	60	40	6	2020/06	0,28	1	5
223.70.30B	2123/45 L	100	70	30	6	2020/06	0,28	1	5
223.30.80B	2123/19 L	110	30	80	6	2020/06	0,30	1	5
223.40.70B	2123/29 L	110	40	70	6	2020/06	0,30	1	5
223.50.60B	2123/39 L	110	50	60	6	2020/06	0,30	1	5
223.60.50B	2123/43 L	110	60	50	6	2020/06	0,30	1	5
223.80.30B	2123/47 L	110	80	30	6	2020/06	0,30	1	5
223.40.80B	2123/30 L	120	40	80	6	2020/06	0,32	1	5
223.60.60B	2123/44 L	120	60	60	6	2020/06	0,32	1	5
223.**.**B.N									Finitura Nera a richiesta
223.**.**B.T									Finitura Ottone a richiesta

DOPPIO CILINDRO CON POMOLO CON CHIAVE CANTIERE

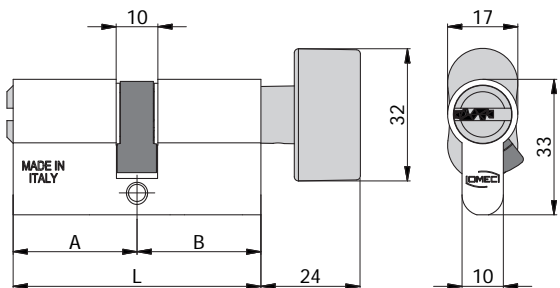

CARATTERISTICHE COSTRUTTIVE:

Corpo in alluminio ad alta resistenza - Barilotto in ottone nichelato con guida-chiave - Perni e controperni in acciaio inox - Molle in acciaio inox - Camma DIN disassata di 30° in acciaio autolubrificante - Pomolo in lega speciale cromo satinata - Chiavi proprietario piatte reversibili in alpaca con numero di codice - Chiave cantiere in ottone con numero di codice.

FUNZIONAMENTO:





Rotazione della chiave o del pomolo di 360°.

PARTI IN DOTAZIONE:

3 chiavi, 1 chiave cantiere, carta di proprietà.

VARIANTI A RICHIESTA:

Impianti speciali KA-MK-GMK-CL.

COD.	EX COD.	L	A	B					
223.30.30B.TK	2123/04 LTK	60	30	30	6	2020/06	0,24	1	10
223.30.35B.TK	2123/13 LTK	65	30	35	6	2020/06	0,24	1	5
223.35.30B.TK	2123/20 LTK	65	35	30	6	2020/06	0,24	1	5
223.30.40B.TK	2123/14 LTK	70	30	40	6	2020/06	0,25	1	5
223.35.35B.TK	2123/07 LTK	70	35	35	6	2020/06	0,25	1	5
223.40.30B.TK	2123/24 LTK	70	40	30	6	2020/06	0,25	1	5
223.30.45B.TK	2123/15 LTK	75	30	45	6	2020/06	0,26	1	5
223.35.40B.TK	2123/21 LTK	75	35	40	6	2020/06	0,26	1	5
223.40.35B.TK	2123/25 LTK	75	40	35	6	2020/06	0,26	1	5
223.45.30B.TK	2123/31 LTK	75	45	30	6	2020/06	0,26	1	5
223.30.50B.TK	2123/16 LTK	80	30	50	6	2020/06	0,27	1	5
223.35.45B.TK	2123/22 LTK	80	35	45	6	2020/06	0,27	1	5
223.40.40B.TK	2123/10 LTK	80	40	40	6	2020/06	0,27	1	5
223.45.35B.TK	2123/32 LTK	80	45	35	6	2020/06	0,27	1	5
223.50.30B.TK	2123/35 LTK	80	50	30	6	2020/06	0,27	1	5
223.35.50B.TK	2123/23 LTK	85	35	50	6	2020/06	0,28	1	5
223.40.45B.TK	2123/26 LTK	85	40	45	6	2020/06	0,28	1	5
223.45.40B.TK	2123/33 LTK	85	45	40	6	2020/06	0,28	1	5
223.50.35B.TK	2123/36 LTK	85	50	35	6	2020/06	0,28	1	5
223.55.30B.TK	2123/46 LTK	85	55	30	6	2020/06	0,28	1	5
223.30.60B.TK	2123/17 LTK	90	30	60	6	2020/06	0,29	1	5
223.40.50B.TK	2123/27 LTK	90	40	50	6	2020/06	0,29	1	5
223.45.45B.TK	2123/34 LTK	90	45	45	6	2020/06	0,29	1	5
223.50.40B.TK	2123/37 LTK	90	50	40	6	2020/06	0,29	1	5
223.60.30B.TK	2123/40 LTK	90	60	30	6	2020/06	0,29	1	5
223.60.35B.TK	2123/41 LTK	95	60	35	6	2020/06	0,30	1	5
223.30.70B.TK	2123/18 LTK	100	30	70	6	2020/06	0,31	1	5
223.40.60B.TK	2123/28 LTK	100	40	60	6	2020/06	0,31	1	5
223.50.50B.TK	2123/38 LTK	100	50	50	6	2020/06	0,31	1	5
223.60.40B.TK	2123/42 LTK	100	60	40	6	2020/06	0,31	1	5
223.70.30B.TK	2123/45 LTK	100	70	30	6	2020/06	0,31	1	5
223.30.80B.TK	2123/19 LTK	110	30	80	6	2020/06	0,33	1	5
223.40.70B.TK	2123/29 LTK	110	40	70	6	2020/06	0,33	1	5
223.50.60B.TK	2123/39 LTK	110	50	60	6	2020/06	0,33	1	5
223.60.50B.TK	2123/43 LTK	110	60	50	6	2020/06	0,33	1	5
223.80.30B.TK	2123/47 LTK	110	80	30	6	2020/06	0,33	1	5
223.40.80B.TK	2123/30 LTK	120	40	80	6	2020/06	0,35	1	5
223.60.60B.TK	2123/44 LTK	120	60	60	6	2020/06	0,35	1	5
223.**.**B.N.TK									Finitura Nera a richiesta
223.**.**B.T.TK									Finitura Ottone a richiesta



1



2

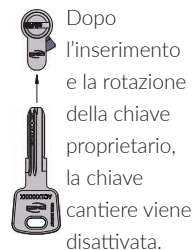

3



DOPPIO CILINDRO CON POMOLO

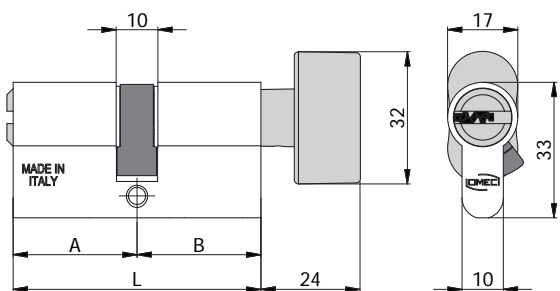

CARATTERISTICHE COSTRUTTIVE:

Corpo in alluminio ad alta resistenza - Barilotto in ottone nichelato con guida-chiave - Perni e controperni in acciaio inox - Molle in acciaio inox - Camma DIN disassata di 30° in acciaio autolubrificante - Pomolo in lega speciale cromo satinata - Chiavi piatte reversibili in alpaca con numero di codice.

FUNZIONAMENTO:





Rotazione della chiave o del pomolo di 360°.

PARTI IN DOTAZIONE:

5 chiavi, carta di proprietà.





VARIANTI A RICHIESTA:

Impianti speciali KA-MK-GMK-CL.

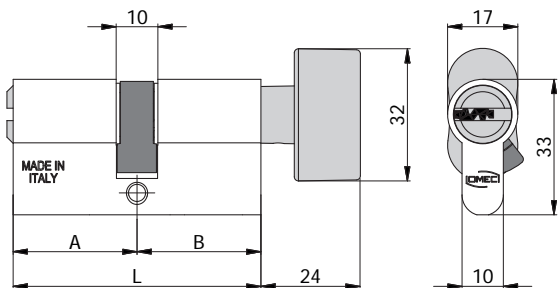
COD.	EX COD.	L	A	B					
223.30.30B.5	2123/504 L	60	30	30	6	2020/06	0,26	1	10
223.30.35B.5	2123/513 L	65	30	35	6	2020/06	0,26	1	5
223.35.30B.5	2123/520 L	65	35	30	6	2020/06	0,26	1	5
223.30.40B.5	2123/514 L	70	30	40	6	2020/06	0,27	1	5
223.35.35B.5	2123/507 L	70	35	35	6	2020/06	0,27	1	5
223.40.30B.5	2123/524 L	70	40	30	6	2020/06	0,27	1	5
223.30.45B.5	2123/515 L	75	30	45	6	2020/06	0,28	1	5
223.35.40B.5	2123/521 L	75	35	40	6	2020/06	0,28	1	5
223.40.35B.5	2123/525 L	75	40	35	6	2020/06	0,28	1	5
223.45.30B.5	2123/531 L	75	45	30	6	2020/06	0,28	1	5
223.30.50B.5	2123/516 L	80	30	50	6	2020/06	0,29	1	5
223.35.45B.5	2123/522 L	80	35	45	6	2020/06	0,29	1	5
223.40.40B.5	2123/510 L	80	40	40	6	2020/06	0,29	1	5
223.45.35B.5	2123/532 L	80	45	35	6	2020/06	0,29	1	5
223.50.30B.5	2123/535 L	80	50	30	6	2020/06	0,29	1	5
223.35.50B.5	2123/523 L	85	35	50	6	2020/06	0,30	1	5
223.40.45B.5	2123/526 L	85	40	45	6	2020/06	0,30	1	5
223.45.40B.5	2123/533 L	85	45	40	6	2020/06	0,30	1	5
223.50.35B.5	2123/536 L	85	50	35	6	2020/06	0,30	1	5
223.55.30B.5	2123/546 L	85	55	30	6	2020/06	0,30	1	5
223.30.60B.5	2123/517 L	90	30	60	6	2020/06	0,31	1	5
223.40.50B.5	2123/527 L	90	40	50	6	2020/06	0,31	1	5
223.45.45B.5	2123/534 L	90	45	45	6	2020/06	0,31	1	5
223.50.40B.5	2123/537 L	90	50	40	6	2020/06	0,31	1	5
223.60.30B.5	2123/540 L	90	60	30	6	2020/06	0,31	1	5
223.60.35B.5	2123/541 L	95	60	35	6	2020/06	0,32	1	5
223.30.70B.5	2123/518 L	100	30	70	6	2020/06	0,33	1	5
223.40.60B.5	2123/528 L	100	40	60	6	2020/06	0,33	1	5
223.50.50B.5	2123/538 L	100	50	50	6	2020/06	0,33	1	5
223.60.40B.5	2123/542 L	100	60	40	6	2020/06	0,33	1	5
223.70.30B.5	2123/545 L	100	70	30	6	2020/06	0,33	1	5
223.30.80B.5	2123/519 L	110	30	80	6	2020/06	0,35	1	5
223.40.70B.5	2123/529 L	110	40	70	6	2020/06	0,35	1	5
223.50.60B.5	2123/539 L	110	50	60	6	2020/06	0,35	1	5
223.60.50B.5	2123/543 L	110	60	50	6	2020/06	0,35	1	5
223.80.30B.5	2123/547 L	110	80	30	6	2020/06	0,35	1	5
223.40.80B.5	2123/530 L	120	40	80	6	2020/06	0,37	1	5
223.60.60B.5	2123/544 L	120	60	60	6	2020/06	0,37	1	5
223.**.**B.N.5									Finitura Nera a richiesta
223.**.**B.T.5									Finitura Ottone a richiesta

DOPPIO CILINDRO CON POMOLO CON CHIAVE CANTIERE



COD.	EX COD.	L	A	B					
223.30.30B.5.TK	2123/504 L TK	60	30	30	6	2020/06	0,28	1	5
223.30.35B.5.TK	2123/513 L TK	65	30	35	6	2020/06	0,28	1	5
223.35.30B.5.TK	2123/520 L TK	65	35	30	6	2020/06	0,28	1	5
223.30.40B.5.TK	2123/514 L TK	70	30	40	6	2020/06	0,29	1	5
223.35.35B.5.TK	2123/507 L TK	70	35	35	6	2020/06	0,29	1	5
223.40.30B.5.TK	2123/524 L TK	70	40	30	6	2020/06	0,29	1	5
223.30.45B.5.TK	2123/515 L TK	75	30	45	6	2020/06	0,30	1	5
223.35.40B.5.TK	2123/521 L TK	75	35	40	6	2020/06	0,30	1	5
223.40.35B.5.TK	2123/525 L TK	75	40	35	6	2020/06	0,30	1	5
223.45.30B.5.TK	2123/531 L TK	75	45	30	6	2020/06	0,30	1	5
223.30.50B.5.TK	2123/516 L TK	80	30	50	6	2020/06	0,31	1	5
223.35.45B.5.TK	2123/522 L TK	80	35	45	6	2020/06	0,31	1	5
223.40.40B.5.TK	2123/510 L TK	80	40	40	6	2020/06	0,31	1	5
223.45.35B.5.TK	2123/532 L TK	80	45	35	6	2020/06	0,31	1	5
223.50.30B.5.TK	2123/535 L TK	80	50	30	6	2020/06	0,31	1	5
223.35.50B.5.TK	2123/523 L TK	85	35	50	6	2020/06	0,32	1	5
223.40.45B.5.TK	2123/526 L TK	85	40	45	6	2020/06	0,32	1	5
223.45.40B.5.TK	2123/533 L TK	85	45	40	6	2020/06	0,32	1	5
223.50.35B.5.TK	2123/536 L TK	85	50	35	6	2020/06	0,32	1	5
223.55.30B.5.TK	2123/546 L TK	85	55	30	6	2020/06	0,32	1	5
223.30.60B.5.TK	2123/517 L TK	90	30	60	6	2020/06	0,33	1	5
223.40.50B.5.TK	2123/527 L TK	90	40	50	6	2020/06	0,33	1	5
223.45.45B.5.TK	2123/534 L TK	90	45	45	6	2020/06	0,33	1	5
223.50.40B.5.TK	2123/537 L TK	90	50	40	6	2020/06	0,33	1	5
223.60.30B.5.TK	2123/540 L TK	90	60	30	6	2020/06	0,33	1	5
223.60.35B.5.TK	2123/541 L TK	95	60	35	6	2020/06	0,34	1	5
223.30.70B.5.TK	2123/518 L TK	100	30	70	6	2020/06	0,35	1	5
223.40.60B.5.TK	2123/528 L TK	100	40	60	6	2020/06	0,35	1	5
223.50.50B.5.TK	2123/538 L TK	100	50	50	6	2020/06	0,35	1	5
223.60.40B.5.TK	2123/542 L TK	100	60	40	6	2020/06	0,35	1	5
223.70.30B.5.TK	2123/545 L TK	100	70	30	6	2020/06	0,35	1	5
223.30.80B.5.TK	2123/519 L TK	110	30	80	6	2020/06	0,37	1	5
223.40.70B.5.TK	2123/529 L TK	110	40	70	6	2020/06	0,37	1	5
223.50.60B.5.TK	2123/539 L TK	110	50	60	6	2020/06	0,37	1	5
223.60.50B.5.TK	2123/543 L TK	110	60	50	6	2020/06	0,37	1	5
223.80.30B.5.TK	2123/547 L TK	110	80	30	6	2020/06	0,37	1	5
223.40.80B.5.TK	2123/530 L TK	120	40	80	6	2020/06	0,39	1	5
223.60.60B.5.TK	2123/544 L TK	120	60	60	6	2020/06	0,39	1	5
223.**.**B.N.5.TK									Finitura Nera a richiesta
223.**.**B.T.5.TK									Finitura Ottone a richiesta



CARATTERISTICHE COSTRUTTIVE:

Corpo in alluminio ad alta resistenza - Barilotto in ottone nichelato con guida-chiave - Perni e controperni in acciaio inox - Molle in acciaio inox - Camma DIN disassata di 30° in acciaio autolubrificante - Pomolo in lega speciale cromo satinata - Chiavi proprietario piatte reversibili in alpaca con numero di codice - Chiave cantiere in ottone con numero di codice.

FUNZIONAMENTO:

Rotazione della chiave o del pomolo di 360°.

PARTI IN DOTAZIONE:

5 chiavi, 1 chiave cantiere, carta di proprietà.

VARIANTI A RICHIESTA:

Impianti speciali KA-MK-GMK-CL.

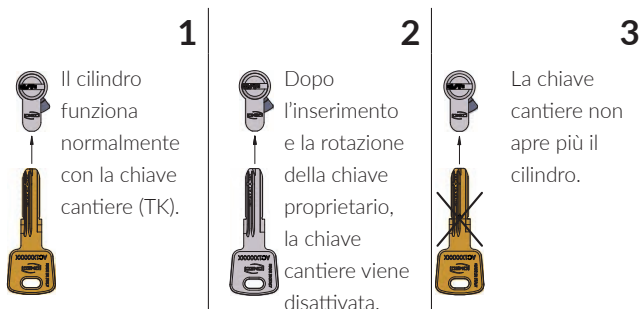

DOPPIO CILINDRO CON GAMBO



CARATTERISTICHE COSTRUTTIVE:

Corpo in alluminio ad alta resistenza - Barilotto in ottone nichelato con guida-chiave - Perni e contoperni in acciaio inox - Molle in acciaio inox - Camma DIN disassata di 30° in acciaio autolubrificante - Gambo in ottone - Chiavi piatte reversibili in alpacca con numero di codice.

FUNZIONAMENTO:

Rotazione della chiave o del pomolo di 360°.





PARTI IN DOTAZIONE:

3 chiavi.

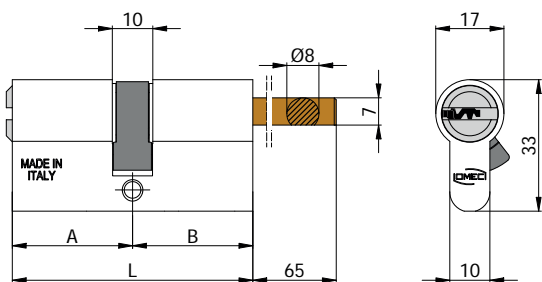
VARIANTI A RICHIESTA:

Impianti speciali KA-MK-GMK-CL.



COD.	EX COD.	L	A	B				
226.30.30G	2126/04 L	60	30	30	6	2020/06	0,18	1 5
226.35.30G	2126/20 L	65	35	30	6	2020/06	0,18	1 5
226.40.30G	2126/24 L	70	40	30	6	2020/06	0,19	1 5
226.45.30G	2126/31 L	75	45	30	6	2020/06	0,20	1 5
226.50.30G	2126/35 L	80	50	30	6	2020/06	0,21	1 5
226.55.30G	2126/46 L	85	55	30	6	2020/06	0,22	1 5
226.60.30G	2126/40 L	90	60	30	6	2020/06	0,23	1 5
226.70.30G	2126/45 L	100	70	30	6	2020/06	0,25	1 5
226.**.**G.N								Finitura Nera a richiesta
226.**.**G.T								Finitura Ottone a richiesta

DOPPIO CILINDRO CON GAMBO CON CHIAVE CANTIERE



CARATTERISTICHE COSTRUTTIVE:

Corpo in alluminio ad alta resistenza - Barilotto in ottone nichelato con guida-chiave - Perni e contoperni in acciaio inox - Molle in acciaio inox - Camma DIN disassata di 30° in acciaio autolubrificante - Gambo in ottone - Chiavi proprietario piatte reversibili in alpacca con numero di codice - Chiave cantiere in ottone con numero di codice.

FUNZIONAMENTO:

Rotazione della chiave o del pomolo di 360°.



PARTI IN DOTAZIONE:

3 chiavi, 1 chiave cantiere, carta di proprietà.

VARIANTI A RICHIESTA:

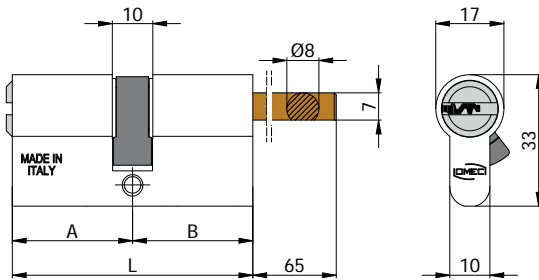
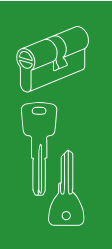
Impianti speciali KA-MK-GMK-CL.



COD.	EX COD.	L	A	B			
226.30.30G.TK	2126/04 L TK	60	30	30	6	2020/06	0,21 1 5
226.35.30G.TK	2126/20 L TK	65	35	30	6	2020/06	0,21 1 5
226.40.30G.TK	2126/24 L TK	70	40	30	6	2020/06	0,22 1 5
226.45.30G.TK	2126/31 L TK	75	45	30	6	2020/06	0,23 1 5
226.50.30G.TK	2126/35 L TK	80	50	30	6	2020/06	0,24 1 5
226.55.30G.TK	2126/46 L TK	85	55	30	6	2020/06	0,25 1 5
226.60.30G.TK	2126/40 L TK	90	60	30	6	2020/06	0,26 1 5
226.70.30G.TK	2126/45 L TK	100	70	30	6	2020/06	0,28 1 5
226.**.**G.N.TK						Finitura Nera a richiesta	
226.**.**G.T.K						Finitura Ottone a richiesta	

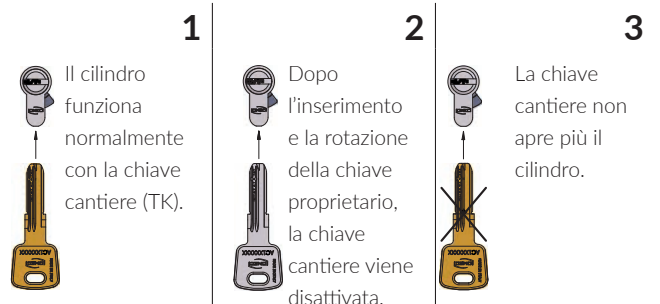

DOPPIO CILINDRO CON GAMBO



CARATTERISTICHE COSTRUTTIVE:

Corpo in alluminio ad alta resistenza - Barilotto in ottone nichelato con guida-chiave - Perni e contoperni in acciaio inox - Molle in acciaio inox - Camma DIN disassata di 30° in acciaio autolubrificante - Gambo in ottone - Chiavi piatte reversibili in alpacca con numero di codice.

FUNZIONAMENTO:

Rotazione della chiave o del pomolo di 360°.



PARTI IN DOTAZIONE:

5 chiavi, carta di proprietà.

VARIANTI A RICHIESTA:

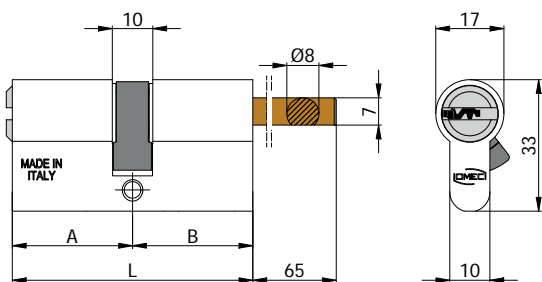
Impianti speciali KA-MK-GMK-CL.



COD.	EX COD.	L	A	B			
226.30.30G.5	2126/504 L	60	30	30	6	2020/06	0,23 1 5
226.35.30G.5	2126/520 L	65	35	30	6	2020/06	0,23 1 5
226.40.30G.5	2126/524 L	70	40	30	6	2020/06	0,24 1 5
226.45.30G.5	2126/531 L	75	45	30	6	2020/06	0,25 1 5
226.50.30G.5	2126/535 L	80	50	30	6	2020/06	0,26 1 5
226.55.30G.5	2126/546 L	85	55	30	6	2020/06	0,27 1 5
226.60.30G.5	2126/540 L	90	60	30	6	2020/06	0,28 1 5
226.70.30G.5	2126/545 L	100	70	30	6	2020/06	0,30 1 5
226.**.**G.N.5							Finitura Nera a richiesta
226.**.**G.T.5							Finitura Ottone a richiesta

DOPPIO CILINDRO CON GAMBO CON CHIAVE CANTIERE



CARATTERISTICHE COSTRUTTIVE:

Corpo in alluminio ad alta resistenza - Barilotto in ottone nichelato con guida-chiave - Perni e contoperni in acciaio inox - Molle in acciaio inox - Camma DIN disassata di 30° in acciaio autolubrificante - Gambo in ottone - Chiavi proprietario piatte reversibili in alpacca con numero di codice - Chiave cantiere in ottone con numero di codice.

FUNZIONAMENTO:

Rotazione della chiave o del pomolo di 360°.





PARTI IN DOTAZIONE:

5 chiavi, 1 chiave cantiere, carta di proprietà.

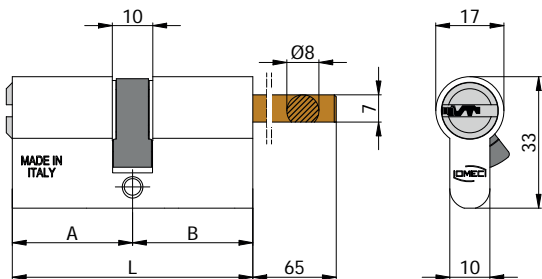
VARIANTI A RICHIESTA:

Impianti speciali KA-MK-GMK-CL.



COD.	EX COD.	L	A	B				
226.30.30G.5.TK	2126/504 L TK	60	30	30	6	2020/06	0,25	1 5
226.35.30G.5.TK	2126/520 L TK	65	35	30	6	2020/06	0,25	1 5
226.40.30G.5.TK	2126/524 L TK	70	40	30	6	2020/06	0,26	1 5
226.45.30G.5.TK	2126/531 L TK	75	45	30	6	2020/06	0,27	1 5
226.50.30G.5.TK	2126/535 L TK	80	50	30	6	2020/06	0,28	1 5
226.55.30G.5.TK	2126/546 L TK	85	55	30	6	2020/06	0,29	1 5
226.60.30G.5.TK	2126/540 L TK	90	60	30	6	2020/06	0,30	1 5
226.70.30G.5.TK	2126/545 L TK	100	70	30	6	2020/06	0,32	1 5
226.**.**G.N.5.TK								Finitura Nera a richiesta
226.**.**G.T.5.TK								Finitura Ottone a richiesta

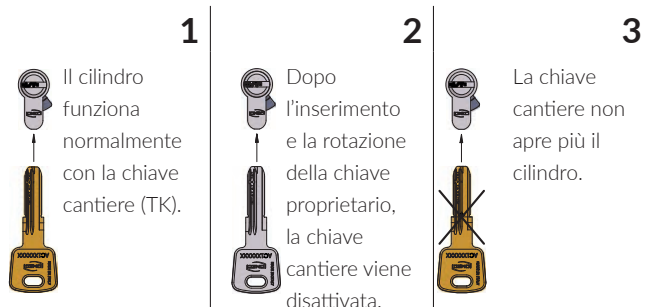

DOPPIO CILINDRO CON GAMBO CORTO

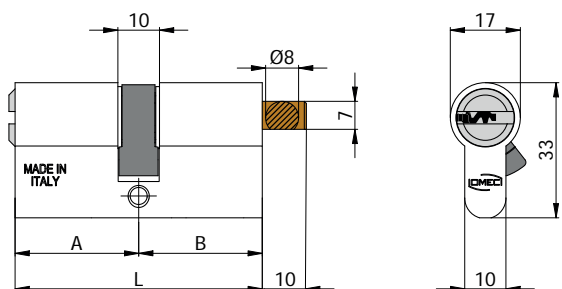

CARATTERISTICHE COSTRUTTIVE:

Corpo in alluminio ad alta resistenza - Barilotto in ottone nichelato con guida-chiave - Perni e controperni in acciaio inox - Molle in acciaio inox - Camma DIN disassata di 30° in acciaio autolubrificante - Gambo in ottone - Chiavi piatte reversibili in alpacca con numero di codice.

FUNZIONAMENTO:

Rotazione della chiave o del pomolo di 360°.

PARTI IN DOTAZIONE:

3 chiavi.

VARIANTI A RICHIESTA:

Impianti speciali KA-MK-GMK-CL.

COD.	L	A	B					
227.30.30G	60	30	30	6	2020/06	0,17	1	10
227.30.35G	65	30	35	6	2020/06	0,17	1	5
227.35.30G	65	35	30	6	2020/06	0,17	1	5
227.30.40G	70	30	40	6	2020/06	0,18	1	5
227.35.35G	70	35	35	6	2020/06	0,18	1	5
227.40.30G	70	40	30	6	2020/06	0,18	1	5
227.30.45G	75	30	45	6	2020/06	0,19	1	5
227.35.40G	75	35	40	6	2020/06	0,19	1	5
227.40.35G	75	40	35	6	2020/06	0,19	1	5
227.45.30G	75	45	30	6	2020/06	0,19	1	5
227.30.50G	80	30	50	6	2020/06	0,20	1	5
227.35.45G	80	35	45	6	2020/06	0,20	1	5
227.40.40G	80	40	40	6	2020/06	0,20	1	5
227.45.35G	80	45	35	6	2020/06	0,20	1	5
227.50.30G	80	50	30	6	2020/06	0,20	1	5
227.35.50G	85	35	50	6	2020/06	0,21	1	5
227.40.45G	85	40	45	6	2020/06	0,21	1	5
227.45.40G	85	45	40	6	2020/06	0,21	1	5
227.50.35G	85	50	35	6	2020/06	0,21	1	5
227.55.30G	85	55	30	6	2020/06	0,21	1	5
227.30.60G	90	30	60	6	2020/06	0,22	1	5
227.40.50G	90	40	50	6	2020/06	0,22	1	5
227.45.45G	90	45	45	6	2020/06	0,22	1	5
227.50.40G	90	50	40	6	2020/06	0,22	1	5
227.60.30G	90	60	30	6	2020/06	0,22	1	5
227.60.35G	95	60	35	6	2020/06	0,23	1	5
227.30.70G	100	30	70	6	2020/06	0,24	1	5
227.40.60G	100	40	60	6	2020/06	0,24	1	5
227.50.50G	100	50	50	6	2020/06	0,24	1	5
227.60.40G	100	60	40	6	2020/06	0,24	1	5
227.70.30G	100	70	30	6	2020/06	0,24	1	5
227.30.80G	110	30	80	6	2020/06	0,26	1	5
227.40.70G	110	40	70	6	2020/06	0,26	1	5
227.50.60G	110	50	60	6	2020/06	0,26	1	5
227.60.50G	110	60	50	6	2020/06	0,26	1	5
227.80.30G	110	80	30	6	2020/06	0,26	1	5
227.40.80G	120	40	80	6	2020/06	0,28	1	5
227.60.60G	120	60	60	6	2020/06	0,28	1	5
227.**.**G.N								Finitura Nera a richiesta
227.**.**G.T								Finitura Ottone a richiesta

DOPPIO CILINDRO CON GAMBO CORTO CON CHIAVE CANTIERE

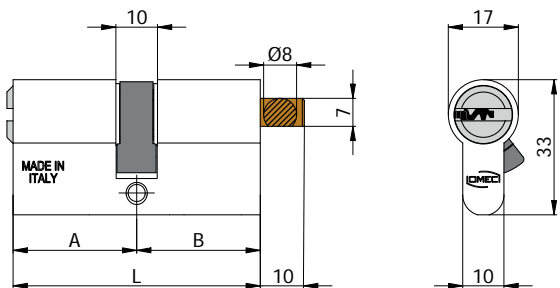

CARATTERISTICHE COSTRUTTIVE:

Corpo in alluminio ad alta resistenza - Barilotto in ottone nichelato con guida-chiave - Perni e controperni in acciaio inox - Molle in acciaio inox - Camma DIN disassata di 30° in acciaio autolubrificante - Gambo in ottone - Chiavi proprietario piatte reversibili in alpaca con numero di codice - Chiave cantiere in ottone con numero di codice.

FUNZIONAMENTO:

Rotazione della chiave o del pomolo di 360°.

PARTI IN DOTAZIONE:

3 chiavi, 1 chiave cantiere, carta di proprietà.

VARIANTI A RICHIESTA:

Impianti speciali KA-MK-GMK-CL.

COD.	L	A	B	Pin	Key	kg	Box	Box
227.30.30G.TK	60	30	30	6	2020/06	0,20	1	10
227.30.35G.TK	65	30	35	6	2020/06	0,20	1	5
227.35.30G.TK	65	35	30	6	2020/06	0,20	1	5
227.30.40G.TK	70	30	40	6	2020/06	0,21	1	5
227.35.35G.TK	70	35	35	6	2020/06	0,21	1	5
227.40.30G.TK	70	40	30	6	2020/06	0,21	1	5
227.30.45G.TK	75	30	45	6	2020/06	0,22	1	5
227.35.40G.TK	75	35	40	6	2020/06	0,22	1	5
227.40.35G.TK	75	40	35	6	2020/06	0,22	1	5
227.45.30G.TK	75	45	30	6	2020/06	0,22	1	5
227.30.50G.TK	80	30	50	6	2020/06	0,23	1	5
227.35.45G.TK	80	35	45	6	2020/06	0,23	1	5
227.40.40G.TK	80	40	40	6	2020/06	0,23	1	5
227.45.35G.TK	80	45	35	6	2020/06	0,23	1	5
227.50.30G.TK	80	50	30	6	2020/06	0,23	1	5
227.35.50G.TK	85	35	50	6	2020/06	0,24	1	5
227.40.45G.TK	85	40	45	6	2020/06	0,24	1	5
227.45.40G.TK	85	45	40	6	2020/06	0,24	1	5
227.50.35G.TK	85	50	35	6	2020/06	0,24	1	5
227.55.30G.TK	85	55	30	6	2020/06	0,24	1	5
227.30.60G.TK	90	30	60	6	2020/06	0,25	1	5
227.40.50G.TK	90	40	50	6	2020/06	0,25	1	5
227.45.45G.TK	90	45	45	6	2020/06	0,25	1	5
227.50.40G.TK	90	50	40	6	2020/06	0,25	1	5
227.60.30G.TK	90	60	30	6	2020/06	0,25	1	5
227.60.35G.TK	95	60	35	6	2020/06	0,26	1	5
227.30.70G.TK	100	30	70	6	2020/06	0,27	1	5
227.40.60G.TK	100	40	60	6	2020/06	0,27	1	5
227.50.50G.TK	100	50	50	6	2020/06	0,27	1	5
227.60.40G.TK	100	60	40	6	2020/06	0,27	1	5
227.70.30G.TK	100	70	30	6	2020/06	0,27	1	5
227.30.80G.TK	110	30	80	6	2020/06	0,29	1	5
227.40.70G.TK	110	40	70	6	2020/06	0,29	1	5
227.50.60G.TK	110	50	60	6	2020/06	0,29	1	5
227.60.50G.TK	110	60	50	6	2020/06	0,29	1	5
227.80.30G.TK	110	80	30	6	2020/06	0,29	1	5
227.40.80G.TK	120	40	80	6	2020/06	0,31	1	5
227.60.60G.TK	120	60	60	6	2020/06	0,31	1	5
227.**.**G.N.TK								Finitura Nera a richiesta
227.**.**G.T.TK								Finitura Ottone a richiesta

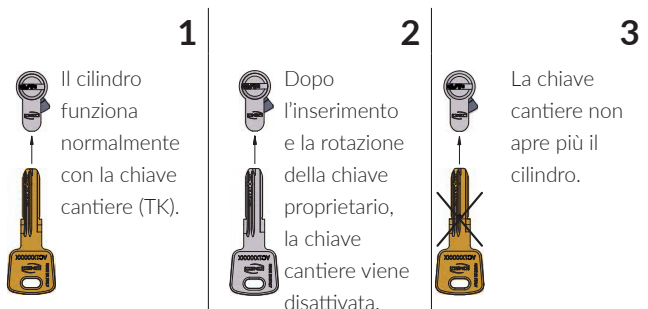

DOPPIO CILINDRO CON GAMBO CORTO

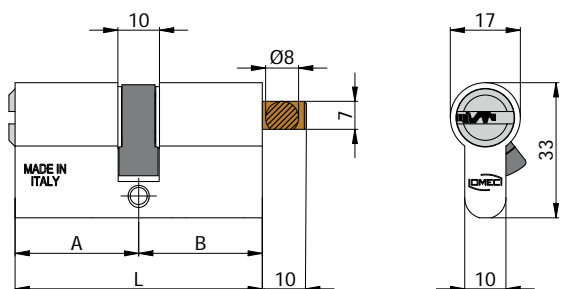

CARATTERISTICHE COSTRUTTIVE:

Corpo in alluminio ad alta resistenza - Barilotto in ottone nichelato con guida-chiave - Perni e controperni in acciaio inox - Molle in acciaio inox - Camma DIN disassata di 30° in acciaio autolubrificante - Gambo in ottone - Chiavi piatte reversibili in alpacca con numero di codice.

FUNZIONAMENTO:

Rotazione della chiave o del pomolo di 360°.

PARTI IN DOTAZIONE:

5 chiavi, carta di proprietà.

VARIANTI A RICHIESTA:

Impianti speciali KA-MK-GMK-CL.

COD.	L	A	B					
227.30.30G.5	60	30	30	6	2020/06	0,22	1	10
227.30.35G.5	65	30	35	6	2020/06	0,22	1	5
227.35.30G.5	65	35	30	6	2020/06	0,22	1	5
227.30.40G.5	70	30	40	6	2020/06	0,23	1	5
227.35.35G.5	70	35	35	6	2020/06	0,23	1	5
227.40.30G.5	70	40	30	6	2020/06	0,23	1	5
227.30.45G.5	75	30	45	6	2020/06	0,24	1	5
227.35.40G.5	75	35	40	6	2020/06	0,24	1	5
227.40.35G.5	75	40	35	6	2020/06	0,24	1	5
227.45.30G.5	75	45	30	6	2020/06	0,24	1	5
227.30.50G.5	80	30	50	6	2020/06	0,25	1	5
227.35.45G.5	80	35	45	6	2020/06	0,25	1	5
227.40.40G.5	80	40	40	6	2020/06	0,25	1	5
227.45.35G.5	80	45	35	6	2020/06	0,25	1	5
227.50.30G.5	80	50	30	6	2020/06	0,25	1	5
227.35.50G.5	85	35	50	6	2020/06	0,26	1	5
227.40.45G.5	85	40	45	6	2020/06	0,26	1	5
227.45.40G.5	85	45	40	6	2020/06	0,26	1	5
227.50.35G.5	85	50	35	6	2020/06	0,26	1	5
227.55.30G.5	85	55	30	6	2020/06	0,26	1	5
227.30.60G.5	90	30	60	6	2020/06	0,27	1	5
227.40.50G.5	90	40	50	6	2020/06	0,27	1	5
227.45.45G.5	90	45	45	6	2020/06	0,27	1	5
227.50.40G.5	90	50	40	6	2020/06	0,27	1	5
227.60.30G.5	90	60	30	6	2020/06	0,27	1	5
227.60.35G.5	95	60	35	6	2020/06	0,28	1	5
227.30.70G.5	100	30	70	6	2020/06	0,29	1	5
227.40.60G.5	100	40	60	6	2020/06	0,29	1	5
227.50.50G.5	100	50	50	6	2020/06	0,29	1	5
227.60.40G.5	100	60	40	6	2020/06	0,29	1	5
227.70.30G.5	100	70	30	6	2020/06	0,29	1	5
227.30.80G.5	110	30	80	6	2020/06	0,31	1	5
227.40.70G.5	110	40	70	6	2020/06	0,31	1	5
227.50.60G.5	110	50	60	6	2020/06	0,31	1	5
227.60.50G.5	110	60	50	6	2020/06	0,31	1	5
227.80.30G.5	110	80	30	6	2020/06	0,31	1	5
227.40.80G.5	120	40	80	6	2020/06	0,33	1	5
227.60.60G.5	120	60	60	6	2020/06	0,33	1	5
227.**.**G.N.5								Finitura Nera a richiesta
227.**.**G.T.5								Finitura Ottone a richiesta

DOPPIO CILINDRO CON GAMBO CORTO CON CHIAVE CANTIERE

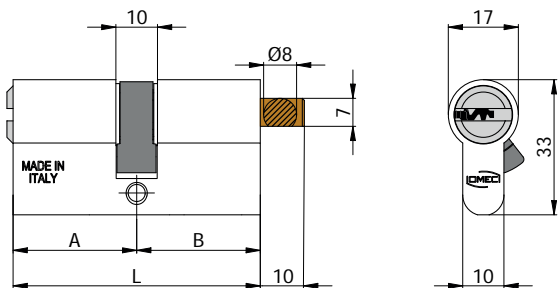

CARATTERISTICHE COSTRUTTIVE:

Corpo in alluminio ad alta resistenza - Barilotto in ottone nichelato con guida-chiave - Perni e controperni in acciaio inox - Molle in acciaio inox - Camma DIN disassata di 30° in acciaio autolubrificante - Gambo in ottone - Chiavi proprietario piatte reversibili in alpaca con numero di codice - Chiave cantiere in ottone con numero di codice.

FUNZIONAMENTO:

Rotazione della chiave o del pomolo di 360°.

PARTI IN DOTAZIONE:

5 chiavi, 1 chiave cantiere, carta di proprietà.

VARIANTI A RICHIESTA:

Impianti speciali KA-MK-GMK-CL.

COD.	L	A	B	Ø	Icona chiave	Icona chiave cantiere	Icona kg	Icona carta	Icona scatola
227.30.30G.5.TK	60	30	30	6	2020/06	0,24	1	5	
227.30.35G.5.TK	65	30	35	6	2020/06	0,24	1	5	
227.35.30G.5.TK	65	35	30	6	2020/06	0,24	1	5	
227.30.40G.5.TK	70	30	40	6	2020/06	0,25	1	5	
227.35.35G.5.TK	70	35	35	6	2020/06	0,25	1	5	
227.40.30G.5.TK	70	40	30	6	2020/06	0,25	1	5	
227.30.45G.5.TK	75	30	45	6	2020/06	0,26	1	5	
227.35.40G.5.TK	75	35	40	6	2020/06	0,26	1	5	
227.40.35G.5.TK	75	40	35	6	2020/06	0,26	1	5	
227.45.30G.5.TK	75	45	30	6	2020/06	0,26	1	5	
227.30.50G.5.TK	80	30	50	6	2020/06	0,27	1	5	
227.35.45G.5.TK	80	35	45	6	2020/06	0,27	1	5	
227.40.40G.5.TK	80	40	40	6	2020/06	0,27	1	5	
227.45.35G.5.TK	80	45	35	6	2020/06	0,27	1	5	
227.50.30G.5.TK	80	50	30	6	2020/06	0,27	1	5	
227.35.50G.5.TK	85	35	50	6	2020/06	0,28	1	5	
227.40.45G.5.TK	85	40	45	6	2020/06	0,28	1	5	
227.45.40G.5.TK	85	45	40	6	2020/06	0,28	1	5	
227.50.35G.5.TK	85	50	35	6	2020/06	0,28	1	5	
227.55.30G.5.TK	85	55	30	6	2020/06	0,28	1	5	
227.30.60G.5.TK	90	30	60	6	2020/06	0,29	1	5	
227.40.50G.5.TK	90	40	50	6	2020/06	0,29	1	5	
227.45.45G.5.TK	90	45	45	6	2020/06	0,29	1	5	
227.50.40G.5.TK	90	50	40	6	2020/06	0,29	1	5	
227.60.30G.5.TK	90	60	30	6	2020/06	0,29	1	5	
227.60.35G.5.TK	95	60	35	6	2020/06	0,30	1	5	
227.30.70G.5.TK	100	30	70	6	2020/06	0,31	1	5	
227.40.60G.5.TK	100	40	60	6	2020/06	0,31	1	5	
227.50.50G.5.TK	100	50	50	6	2020/06	0,31	1	5	
227.60.40G.5.TK	100	60	40	6	2020/06	0,31	1	5	
227.70.30G.5.TK	100	70	30	6	2020/06	0,31	1	5	
227.30.80G.5.TK	110	30	80	6	2020/06	0,33	1	5	
227.40.70G.5.TK	110	40	70	6	2020/06	0,33	1	5	
227.50.60G.5.TK	110	50	60	6	2020/06	0,33	1	5	
227.60.50G.5.TK	110	60	50	6	2020/06	0,33	1	5	
227.80.30G.5.TK	110	80	30	6	2020/06	0,33	1	5	
227.40.80G.5.TK	120	40	80	6	2020/06	0,35	1	5	
227.60.60G.5.TK	120	60	60	6	2020/06	0,35	1	5	
227.**.**G.N.5.TK									Finitura Nera a richiesta
227.**.**G.T.5.TK									Finitura Ottone a richiesta

