

354

Flat striking plates

360

Nylon striking plates

372

Metal striking plates

387

Stainless steel
adjustable striking plates



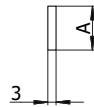
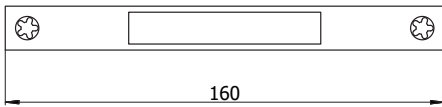

For locks series:

- 1770 - 1775 - 1870
- 370 - 375 - 378
- 770 - 775 - 778 - 782
- 870 - 875 - 878 - 882

COD.	A	Material			
01611 A	16	Chrome-plated steel	0,033	50	-
02211 A	22	Chrome-plated steel	0,054	50	-

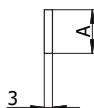
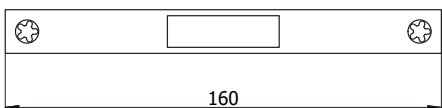

For locks series:

- 1771 - 1777 - 1780 - 1781 - 1785
- 371 - 377 - 380 - 381 - 385 - 388 - 390 - 391 - 395
- 771 - 777 - 780 - 781 - 785 - 788 - 790 - 791 - 795
- 871 - 877 - 880 - 881 - 885 - 888 - 890 - 891 - 895
- 990 - 991 - 995

COD.	A	Material			
01613 A	16	Chrome-plated steel	0,046	50	-
02213 A	22	Chrome-plated steel	0,067	50	-

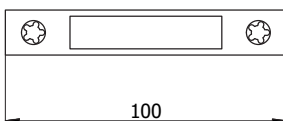

For locks series:

- 1301
- 334 - 335 - 339 - 354 - 355 - 359
- 4335 - 4339 - 4355 - 4531
- 531 - 541

COD.	A	Material			
01614 A	16	Chrome-plated steel	0,021	50	-
02214 A	22	Chrome-plated steel	0,034	50	-

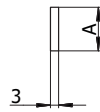
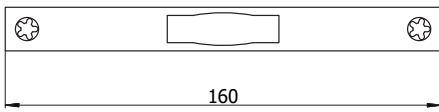

For locks series:

345

COD.	A	Material	kg		
01615 A	16	Chrome-plated steel	0,046	50	-
02215 A	22	Chrome-plated steel	0,048	50	-

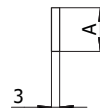
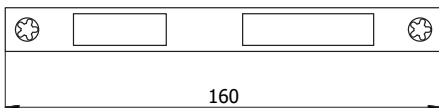

For locks series:

1300 - 1305
 328 - 330 - 332 - 338 - 348 - 350 - 352 - 358
 4328 - 4330 - 4338 - 4350 - 4530 - 4535
 530 - 535 - 540 - 545

COD.	A	Material	kg		
01616 A	16	Chrome-plated steel	0,036	50	-
02216 A	22	Chrome-plated steel	0,048	50	-

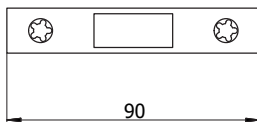

For locks series:

1776
 327 - 337 - 351 - 356 - 357
 376 - 386 - 396 - 399
 4356
 776 - 786 - 796 - 799
 899
 999

COD.	A	Material	kg		
01619 A	16	Chrome-plated steel	0,024	50	-
02219 A	22	Chrome-plated steel	0,038	50	-

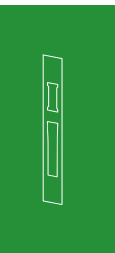

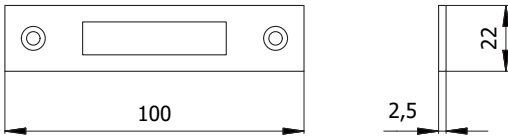

For locks series:

4621/F20

COD.	Material	kg		
02014 A	Nickel - plated steel	0,029	50	-

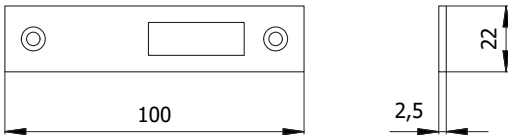

For locks series:

4626/F20

COD.	Material	kg		
02019 A	Nickel - plated steel	0,032	50	-

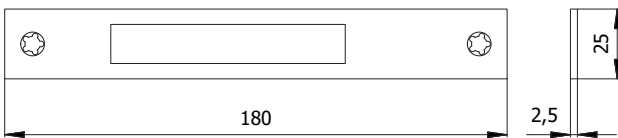

For locks series:

11140 - 11141 - 11145 - 11170 - 11171 - 11175
 1940 - 1941 - 1945 - 1970 - 1971 - 1975
 41140 - 41141 - 41145 - 41170 - 41171 - 41175
 4940 - 4941 - 4945 - 4970 - 4971 - 4975
 5930 - 5931 - 5935 - 5938 - 5940 - 5941 - 5945 - 5948
 5950 - 5951 - 5960 - 5961 - 5965 - 5968 - 5970 - 5971
 5975 - 5978 - 5980 - 5981

COD.	Material	kg		
02521 X	Stainless steel	0,062	50	-

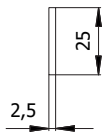
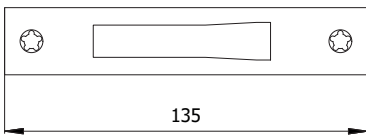

For locks series:

1401 - 1406 - 1411 - 1416 - 1473 - 1491 - 1496
 1501 - 1506 - 1531 - 1541
 4401 - 4406 - 4411 - 4416 - 4473 - 4491 - 4496

For deviators series:

0661 - 0662

For deviators of multi-point locks with tipping dead bolt

COD.	Material	kg		
02524 X	Stainless steel	0,046	50	-

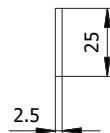
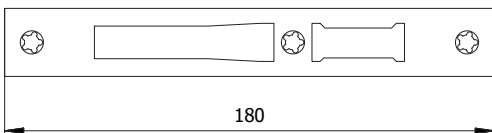

For locks series:

1300 - 1305
 1400 - 1405 - 1408Q - 1409Q - 1410 - 1415 - 1418Q
 1490 - 1495
 1500 - 1505 - 1508Q
 4400 - 4405 - 4408Q - 4409Q - 4410 - 4415 - 4418Q
 4490 - 4495

COD.	Material	kg		
02526 X	Stainless steel	0,060	50	-

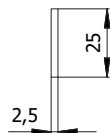
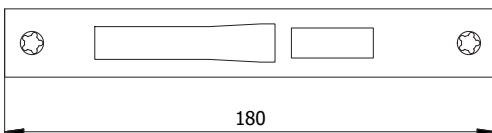

For locks series:

1408 - 1409 - 1418
 1508
 4408 - 4409 - 4418

COD.	Material	kg		
02528 X	Stainless steel	0,064	50	-

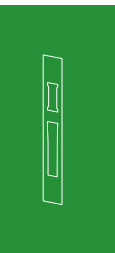

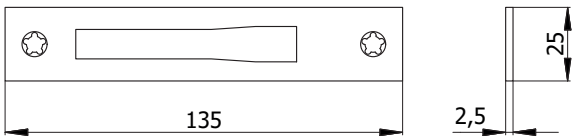

For locks series:

1401S - 1411S
1501S
1601S - 1611S - 1621S - 1631S
1701S - 1721S - 1741S - 1761S

For deviators series:

0661S - 0761S

For deviators of vertical multi-point locks with gear mechanism movements

(but series 1740S - 1760S)

COD.	Material	kg		
02544 X	Stainless steel	0,051	50	-

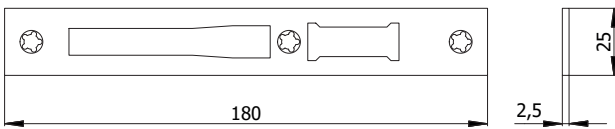

For locks series:

1400S - 1405S - 1410S - 1415S
1500S - 1505S
1600S - 1605S - 1610S - 1615S
1620S - 1625S - 1630S - 1635S
1700S - 1705S - 1720S - 1725S
1740S - 1745S - 1760S - 1765S

COD.	Material	kg		
02546 X	Stainless steel	0,065	50	-

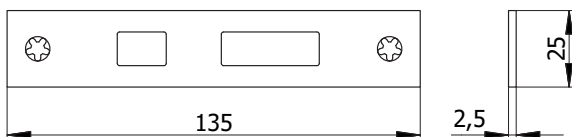

For deviators series:

0766S

For deviators of vertical multi-point locks with gear mechanism movements:

1740S - 1760S

COD.	Material	kg		
02549 X	Stainless steel	0,051	50	-



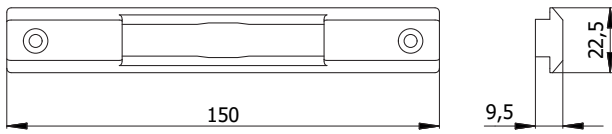

For locks series:

- 1301
- 1770 - 1771 - 1777 - 1780 - 1781 - 1785 - 1870
- 327 - 334 - 335 - 337 - 339 - 351 - 354 - 355 - 357 - 359
- 370 - 371 - 377 - 378 - 380 - 381 - 385 - 388
- 390 - 391 - 395 - 399
- 4335 - 4339 - 4355 - 4531
- 531 - 541
- 770 - 771 - 777 - 778 - 780 - 781 - 782 - 785 - 788
- 790 - 791 - 795 - 799
- 870 - 871 - 877 - 878 - 880 - 881 - 882 - 885 - 888
- 890 - 891 - 895 - 899
- 990 - 991 - 995 - 999

For profiles type:

Domal Stopper PG Finestra
NC 45 Int. Finestra

COD.	Material			
02381 N	Black nylon	0,011	20	-

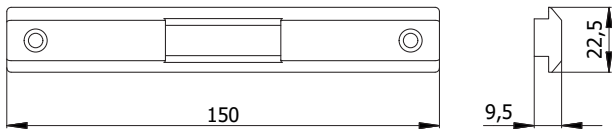

For locks series:

- 1301
- 1771 - 1777 - 1780 - 1781 - 1785
- 327 - 337 - 351 - 357
- 371 - 377 - 380 - 381 - 385 - 388 - 390 - 391 - 395 - 399
- 771 - 777 - 780 - 781 - 785 - 788 - 790 - 791 - 795 - 799
- 871 - 877 - 880 - 881 - 885 - 888 - 890 - 891 - 895 - 899
- 990 - 991 - 995 - 999

For profiles type:

Domal Stopper PG Finestra
NC 45 Int. Finestra

COD.	Material			
02383 N	Black nylon	0,014	20	-

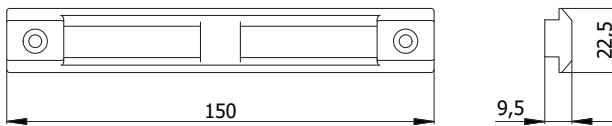

For locks series:

- 330 - 332 - 338 - 350 - 352 - 358
- 4330 - 4338 - 4350 - 4530
- 530 - 540

For profiles type:

Domal Stopper PG Finestra
NC 45 Int. Finestra

COD.	Material			
02386 N	Black nylon	0,011	20	-

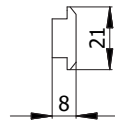
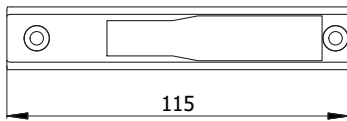

For locks series:

- 11141 - 11171
- 1401 - 1401S - 1411 - 1411S
- 1501 - 1501S
- 1941 - 1971
- 41141 - 41171
- 4401 - 4411
- 4941 - 4971
- 5931 - 5941 - 5948 - 5951 - 5961 - 5971 - 5978 - 5981

For deviators series:

- 0661 - 0661S - 0662

For deviators of multi-point locks with tipping dead bolt

For profiles type:

Domal Stopper PG Finestra
NC 45 Int. Finestra

COD.	Material	kg		
02394 N	Black nylon	0,008	20	-

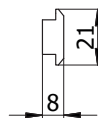
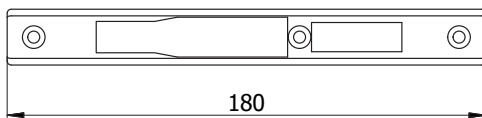

For locks series:

- 1300 - 1305
- 1400 - 1400S - 1405 - 1405S - 1408Q - 1409Q - 1410 - 1410S - 1415 - 1415S - 1418Q
- 1500 - 1500S - 1505 - 1505S - 1508Q
- 4400 - 4405 - 4408Q - 4409Q - 4410 - 4415 - 4418Q
- 5930 - 5935 - 5960 - 5965

For profiles type:

Domal Stopper PG Finestra
NC 45 Int. Finestra

COD.	Material	kg		
02396 N	Black nylon	0,008	20	-

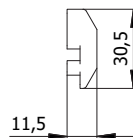
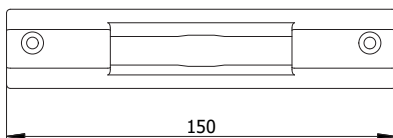

For locks series:

- 1301
- 1770 - 1771 - 1777 - 1780 - 1781 - 1785 - 1870
- 327 - 334 - 335 - 337 - 339 - 351 - 354 - 355 - 357 - 359
- 370 - 371 - 377 - 378 - 380 - 381 - 385 - 388
- 390 - 391 - 395 - 399
- 4335 - 4339 - 4355 - 4531
- 531 - 541
- 770 - 771 - 777 - 778 - 780 - 781 - 782 - 785 - 788
- 790 - 791 - 795 - 799
- 870 - 871 - 877 - 878 - 880 - 881 - 882 - 885 - 888
- 890 - 891 - 895 - 899
- 990 - 991 - 995 - 999

For profiles type:

R 40, R 50

COD.	Material	kg		
02881 N	Black nylon	0,024	20	-

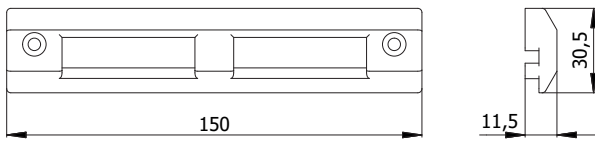

For locks series:

330 - 332 - 338 - 350 - 352 - 358
 4330 - 4338 - 4350 - 4530
 530 - 540

For profiles type:

R 40, R 50

COD.	Material			
02886 N	Black nylon	0,024	20	-

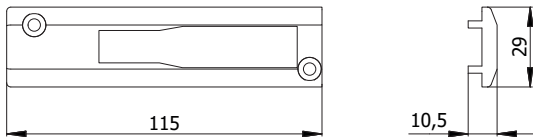

For locks series:

11141 - 11171
 1401 - 1401S - 1411 - 1411S
 1501 - 1501S
 1941 - 1971
 41141 - 41171
 4401 - 4411
 4941 - 4971
 5931 - 5941 - 5948 - 5951 - 5961 - 5971 - 5978 - 5981

For deviators series:

0661 - 0661S - 0662

For deviators of multi-point locks with tipping dead bolt

For profiles type:

R 40, R 50

COD.	Material			
02894 N	Black nylon	0,013	20	-

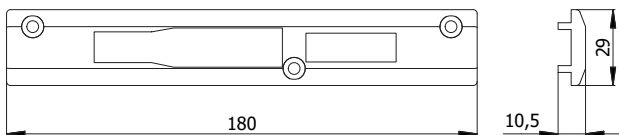

For locks series:

1300 - 1305
 1400 - 1400S - 1405 - 1405S - 1408Q - 1409Q - 1410 - 1410S -
 1415 - 1415S - 1418Q
 1500 - 1500S - 1505 - 1505S - 1508Q
 4400 - 4405 - 4408Q - 4409Q - 4410 - 4415 - 4418Q
 5930 - 5935 - 5960 - 5965

For profiles type:

R 40, R 50

COD.	Material			
02896 N	Black nylon	0,019	20	-

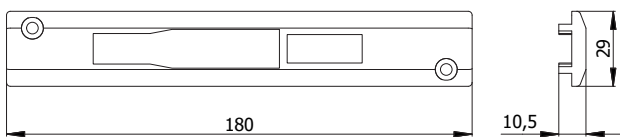

For locks series:

- 11140 - 11145 - 11170 - 11175
- 1408 - 1409 - 1418
- 1508
- 1940 - 1945 - 1970 - 1975
- 41140 - 41145 - 41170 - 41175
- 4408 - 4409 - 4418
- 4940 - 4945 - 4970 - 4975
- 5938 - 5940 - 5945 - 5950 - 5968 - 5970 - 5975 - 5980

For profiles type:

R 40, R 50

COD.	Material			
02898 N	Black nylon	0,021	20	-

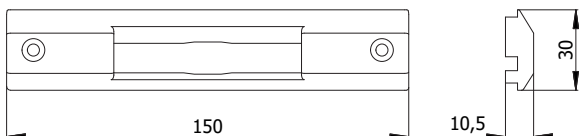

For locks series:

- 1301
- 1770 - 1771 - 1777 - 1780 - 1781 - 1785 - 1870
- 327 - 334 - 335 - 337 - 339 - 351 - 354 - 355 - 357 - 359
- 370 - 371 - 377 - 378 - 380 - 381 - 385 - 388
- 390 - 391 - 395 - 399
- 4335 - 4339 - 4355 - 4531
- 531 - 541
- 770 - 771 - 777 - 778 - 780 - 781 - 782 - 785 - 788
- 790 - 791 - 795 - 799
- 870 - 871 - 877 - 878 - 880 - 881 - 882 - 885 - 888
- 890 - 891 - 895 - 899
- 990 - 991 - 995 - 999

For profiles type:

Nuovo NC 40 Sormonto 1 anta

COD.	Material			
02981 N	Black nylon	0,019	20	-

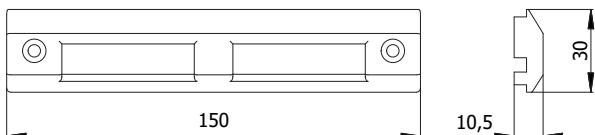

For locks series:

- 330 - 332 - 338 - 350 - 352 - 358
- 4330 - 4338 - 4350 - 4530
- 530 - 540

For profiles type:

Nuovo NC 40 Sormonto 1 anta

COD.	Material			
02986 N	Black nylon	0,018	20	-



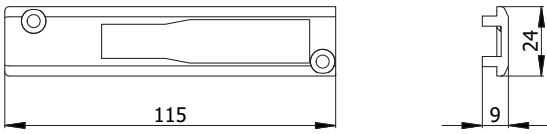

For locks series:

- 11141 - 11171
- 1401 - 1401S - 1411 - 1411S
- 1501 - 1501S
- 1941 - 1971
- 41141 - 41171
- 4401 - 4411
- 4941 - 4971
- 5931 - 5941 - 5948 - 5951 - 5961 - 5971 - 5978 - 5981

For deviators series:

- 0661 - 0661S - 0662

For deviators of multi-point locks with tipping dead bolt

For profiles type:

Nuovo NC 40 Sormonto 1 anta

COD.	Material			
02994 N	Black nylon	0,009	20	-

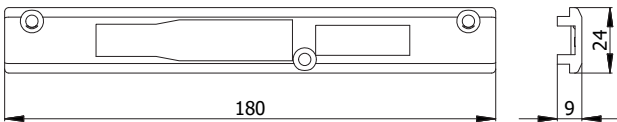

For locks series:

- 1300 - 1305
- 1400 - 1400S - 1405 - 1405S - 1408Q - 1409Q - 1410 - 1410S - 1415 - 1415S - 1418Q
- 1500 - 1500S - 1505 - 1505S - 1508Q
- 4400 - 4405 - 4408Q - 4409Q - 4410 - 4415 - 4418Q
- 5930 - 5935 - 5960 - 5965

For profiles type:

Nuovo NC 40 Sormonto 1 anta

COD.	Material			
02996 N	Black nylon	0,015	20	-

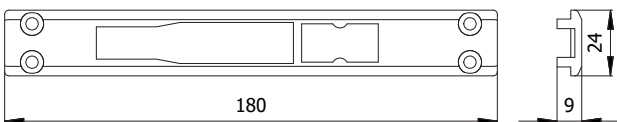

For locks series:

- 11140 - 11145 - 11170 - 11175
- 1408 - 1409 - 1418
- 1508
- 1940 - 1945 - 1970 - 1975
- 41140 - 41145 - 41170 - 41175
- 4408 - 4409 - 4418
- 4940 - 4945 - 4970 - 4975
- 5938 - 5940 - 5945 - 5950 - 5968 - 5970 - 5975 - 5980

For profiles type:

Nuovo NC 40 Sormonto 1 anta

COD.	Material			
02998 N	Black nylon	0,015	20	-

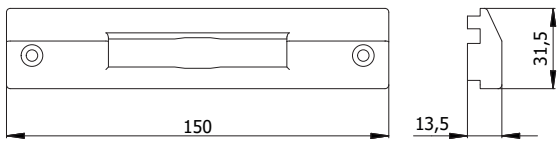

For locks series:

- 1301
- 1770 - 1771 - 1777 - 1780 - 1781 - 1785 - 1870
- 327 - 334 - 335 - 337 - 339 - 351 - 354 - 355 - 357 - 359
- 370 - 371 - 377 - 378 - 380 - 381 - 385 - 388
- 390 - 391 - 395 - 399
- 4335 - 4339 - 4355 - 4531
- 531 - 541
- 770 - 771 - 777 - 778 - 780 - 781 - 782 - 785 - 788
- 790 - 791 - 795 - 799
- 870 - 871 - 877 - 878 - 880 - 881 - 882 - 885 - 888
- 890 - 891 - 895 - 899
- 990 - 991 - 995 - 999

For profiles type:

All.co 5 Sormonto

COD.	Material	kg		
03281 N	Black nylon	0,031	20	-

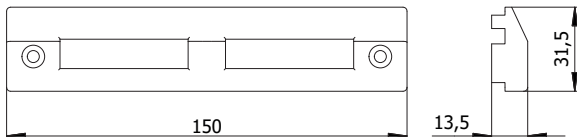

For locks series:

- 330 - 332 - 338 - 350 - 352 - 358
- 4330 - 4338 - 4350 - 4530
- 530 - 540

For profiles type:

All.co 5 Sormonto

COD.	Material	kg		
03286 N	Black nylon	0,034	20	-

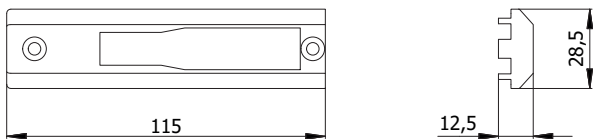

For locks series:

- 11141 - 11171
- 1401 - 1401S - 1411 - 1411S
- 1501 - 1501S
- 1941 - 1971
- 41141 - 41171
- 4401 - 4411
- 4941 - 4971
- 5931 - 5941 - 5948 - 5951 - 5961 - 5971 - 5978 - 5981

For deviators series:

- 0661 - 0661S - 0662

For deviators of multi-point locks with tipping dead bolt

For profiles type:

All.co 5 Sormonto

COD.	Material	kg		
03294 N	Black nylon	0,017	20	-

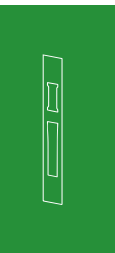

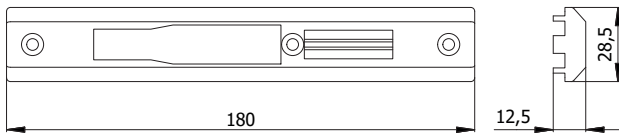

For locks series:

- 1300 - 1305
- 1400 - 1400S - 1405 - 1405S - 1408Q - 1409Q - 1410 - 1410S - 1415 - 1415S - 1418Q
- 1500 - 1500S - 1505 - 1505S - 1508Q
- 4400 - 4405 - 4408Q - 4409Q - 4410 - 4415 - 4418Q
- 5930 - 5935 - 5960 - 5965

For profiles type:

All.co 5 Sormonto

COD.	Material			
03296 N	Black nylon	0,028	20	-

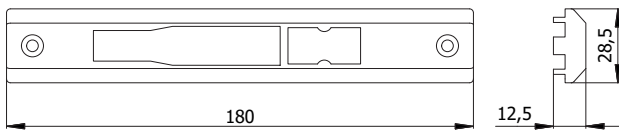

For locks series:

- 11140 - 11145 - 11170 - 11175
- 1408 - 1409 - 1418
- 1508
- 1940 - 1945 - 1970 - 1975
- 41140 - 41145 - 41170 - 41175
- 4408 - 4409 - 4418
- 4940 - 4945 - 4970 - 4975
- 5938 - 5940 - 5945 - 5950 - 5968 - 5970 - 5975 - 5980

For profiles type:

All.co 5 Sormonto

COD.	Material			
03298 N	Black nylon	0,030	20	-

HORIZONTAL ADJUSTMENT

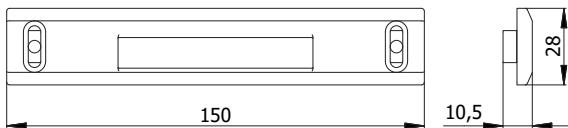

For locks series:

- 1301
- 1770 - 1771 - 1777 - 1780 - 1781 - 1785 - 1870
- 327 - 334 - 335 - 337 - 339 - 351 - 354 - 355 - 357 - 359
- 370 - 371 - 377 - 378 - 380 - 381 - 385 - 388
- 390 - 391 - 395 - 399
- 4335 - 4339 - 4355 - 4531
- 531 - 541
- 770 - 771 - 777 - 778 - 780 - 781 - 782 - 785 - 788
- 790 - 791 - 795 - 799
- 870 - 871 - 877 - 878 - 880 - 881 - 882 - 885 - 888
- 890 - 891 - 895 - 899
- 990 - 991 - 995 - 999

For profiles type:

R 40, R 50, Domal Stopper
PG Finestra, Nuovo NC 40
Sormonto 2 ante con riporto

COD.	Material			
03781 N	Black nylon	0,018	10	-

HORIZONTAL ADJUSTMENT

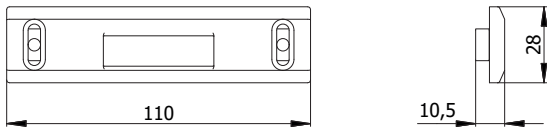

For locks series:

- 1301
- 1771 - 1777 - 1780 - 1781 - 1785
- 327 - 337 - 351 - 357
- 371 - 377 - 380 - 381 - 385 - 388 - 390 - 391 - 395 - 399
- 771 - 777 - 780 - 781 - 785 - 788 - 790 - 791 - 795 - 799
- 871 - 877 - 880 - 881 - 885 - 888 - 890 - 891 - 895 - 899
- 990 - 991 - 995 - 999

For profiles type:

R 40, R 50, Domal Stopper
PG Finestra, Nuovo NC 40
Sormonto 2 ante con riporto

COD.	Material			
03783 N	Black nylon	0,022	10	-

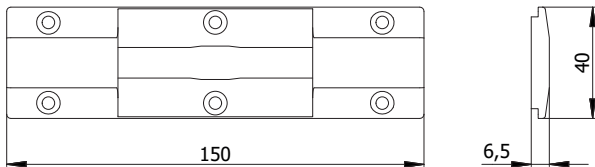

For locks series:

- 1301
- 1770 - 1771 - 1777 - 1780 - 1781 - 1785 - 1870
- 327 - 334 - 335 - 337 - 339 - 351 - 354 - 355 - 357 - 359
- 370 - 371 - 377 - 378 - 380 - 381 - 385 - 388
- 390 - 391 - 395 - 399
- 4335 - 4339 - 4355 - 4531
- 531 - 541
- 770 - 771 - 777 - 778 - 780 - 781 - 782 - 785 - 788
- 790 - 791 - 795 - 799
- 870 - 871 - 877 - 878 - 880 - 881 - 882 - 885 - 888
- 890 - 891 - 895 - 899
- 990 - 991 - 995 - 999

For profiles type:

NC 40

COD.	Material			
04061 N	Black nylon	0,021	20	-

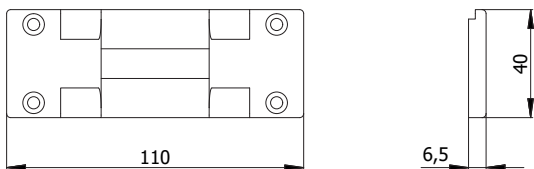

For locks series:

- 1301
- 1771 - 1777 - 1780 - 1781 - 1785
- 327 - 337 - 351 - 357
- 371 - 377 - 380 - 381 - 385 - 388 - 390 - 391 - 395 - 399
- 771 - 777 - 780 - 781 - 785 - 788 - 790 - 791 - 795 - 799
- 871 - 877 - 880 - 881 - 885 - 888 - 890 - 891 - 895 - 899
- 990 - 991 - 995 - 999

For profiles type:

NC 40

COD.	Material			
04063 N	Black nylon	0,017	20	-

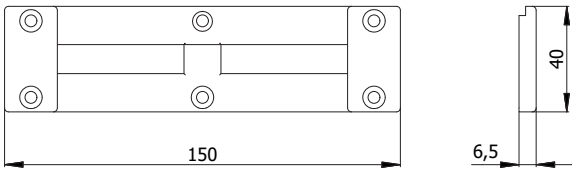

For locks series:

330 - 332 - 338 - 350 - 352 - 358
 4330 - 4338 - 4350 - 4530
 530 - 540

For profiles type:

NC 40

COD.	Material	kg		
04066 N	Black nylon	0,021	20	-

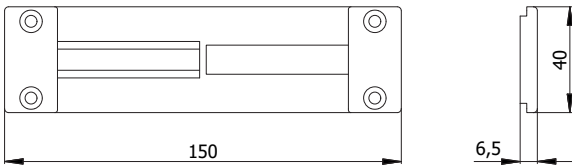

For locks series:

1775
 320 - 322 - 328 - 340 - 342 - 345 - 348
 375
 4320 - 4328 - 4340 - 4535
 535 - 545
 775
 875

For profiles type:

NC 40

COD.	Material	kg		
04067 N	Black nylon	0,021	20	-

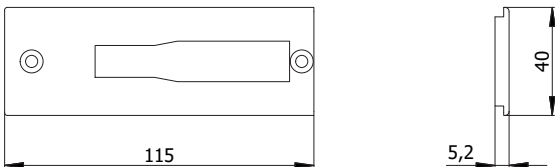

For locks series:

11141 - 11171
 1401 - 1401S - 1411 - 1411S
 1501 - 1501S
 1941 - 1971
 41141 - 41171
 4401 - 4411
 4941 - 4971
 5931 - 5941 - 5948 - 5951 - 5961 - 5971 - 5978 - 5981

For deviators series:

0661 - 0661S - 0662

For deviators of multi-point locks with tipping dead bolt

For profiles type:

NC 40

COD.	Material	kg		
04094 N	Black nylon	0,011	20	-

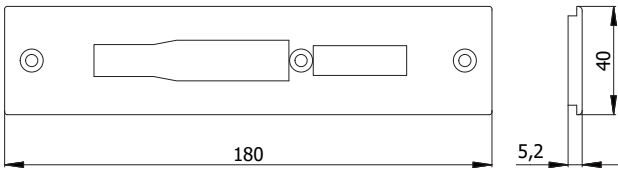

For locks series:

- 1300 - 1305
- 1400 - 1400S - 1405 - 1405S - 1408Q - 1409Q - 1410 - 1410S - 1415 - 1415S - 1418Q
- 1500 - 1500S - 1505 - 1505S - 1508Q
- 4400 - 4405 - 4408Q - 4409Q - 4410 - 4415 - 4418Q
- 5930 - 5935 - 5960 - 5965

For profiles type:

NC 40

COD.	Material			
04096 N	Black nylon	0,016	20	-

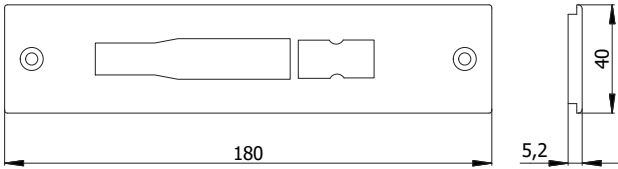

For locks series:

- 11140 - 11145 - 11170 - 11175
- 1408 - 1409 - 1418
- 1508
- 1940 - 1945 - 1970 - 1975
- 41140 - 41145 - 41170 - 41175
- 4408 - 4409 - 4418
- 4940 - 4945 - 4970 - 4975
- 5938 - 5940 - 5945 - 5950 - 5968 - 5970 - 5975 - 5980

For profiles type:

NC 40

COD.	Material			
04098 N	Black nylon	0,020	20	-

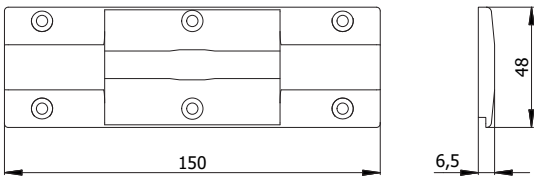

For locks series:

- 1301
- 1770 - 1771 - 1777 - 1780 - 1781 - 1785 - 1870
- 327 - 334 - 335 - 337 - 339 - 351 - 354 - 355 - 357 - 359
- 370 - 371 - 377 - 378 - 380 - 381 - 385 - 388
- 390 - 391 - 395 - 399
- 4335 - 4339 - 4355 - 4531
- 531 - 541
- 770 - 771 - 777 - 778 - 780 - 781 - 782 - 785 - 788
- 790 - 791 - 795 - 799
- 870 - 871 - 877 - 878 - 880 - 881 - 882 - 885 - 888
- 890 - 891 - 895 - 899
- 990 - 991 - 995 - 999

For profiles type:

NC 50 B

COD.	Material			
05061 N	Black nylon	0,023	20	-

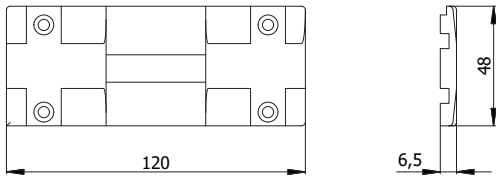

For locks series:

1301
 1771 - 1777 - 1780 - 1781 - 1785
 327 - 337 - 351 - 357
 371 - 377 - 380 - 381 - 385 - 388 - 390 - 391 - 395 - 399
 771 - 777 - 780 - 781 - 785 - 788 - 790 - 791 - 795 - 799
 871 - 877 - 880 - 881 - 885 - 888 - 890 - 891 - 895 - 899
 990 - 991 - 995 - 999

For profiles type:

NC 50 B

COD.	Material	kg		
05063 N	Black nylon	0,030	20	-

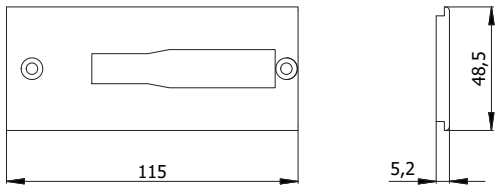

For locks series:

11141 - 11171
 1401 - 1401S - 1411 - 1411S
 1501 - 1501S
 1941 - 1971
 41141 - 41171
 4401 - 4411
 4941 - 4971
 5931 - 5941 - 5948 - 5951 - 5961 - 5971 - 5978 - 5981

For deviators series:

0661 - 0661S - 0662

For deviators of multi-point locks with tipping dead bolt

For profiles type:

NC 50 B

COD.	Material	kg		
05094 N	Black nylon	0,014	20	-

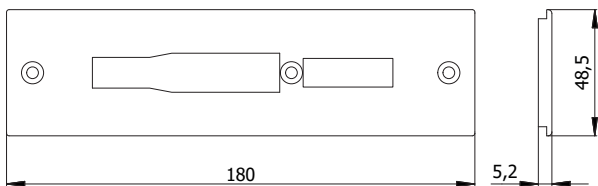

For locks series:

1300 - 1305
 1400 - 1400S - 1405 - 1405S - 1408Q - 1409Q - 1410 - 1410S -
 1415 - 1415S - 1418Q
 1500 - 1500S - 1505 - 1505S - 1508Q
 4400 - 4405 - 4408Q - 4409Q - 4410 - 4415 - 4418Q
 5930 - 5935 - 5960 - 5965

For profiles type:

NC 50 B

COD.	Material	kg		
05096 N	Black nylon	0,022	20	-



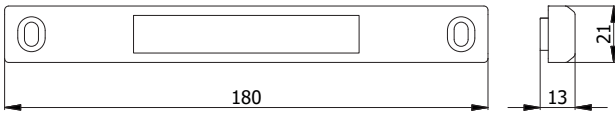

For locks series:

- 11140 - 11141 - 11145 - 11170 - 11171 - 11175
- 1940 - 1941 - 1945 - 1970 - 1971 - 1975
- 41140 - 41141 - 41145 - 41170 - 41171 - 41175
- 4940 - 4941 - 4945 - 4970 - 4971 - 4975
- 5930 - 5931 - 5935 - 5938 - 5940 - 5941 - 5945 - 5948
- 5950 - 5951 - 5960 - 5961 - 5965 - 5968 - 5970 - 5971
- 5975 - 5978 - 5980 - 5981

For profiles type:

All.co 5

COD.	Material	kg		
02121 L	Painted special alloy	0,151	20	-

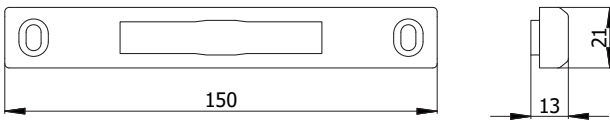

For locks series:

- 1301
- 1770 - 1771 - 1777 - 1780 - 1781 - 1785 - 1870
- 327 - 334 - 335 - 337 - 339 - 351 - 354 - 355 - 357 - 359
- 370 - 371 - 377 - 378 - 380 - 381 - 385 - 388
- 390 - 391 - 395 - 399
- 4335 - 4339 - 4355 - 4531
- 531 - 541
- 770 - 771 - 777 - 778 - 780 - 781 - 782 - 785 - 788
- 790 - 791 - 795 - 799
- 870 - 871 - 877 - 878 - 880 - 881 - 882 - 885 - 888
- 890 - 891 - 895 - 899
- 990 - 991 - 995 - 999

For profiles type:

All.co 5

COD.	Material	kg		
02181 L	Painted special alloy	0,136	20	-

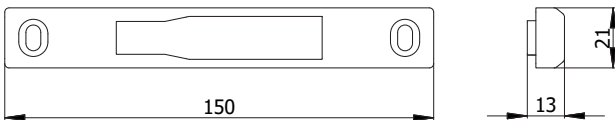

For locks series:

- 1401 - 1401S - 1411 - 1411S
- 1501 - 1501S
- 4401 - 4411

For deviators series:

- 0661 - 0661S - 0662

For deviators of multi-point locks with tipping dead bolt

For profiles type:

All.co 5

COD.	Material	kg		
02194 L	Painted special alloy	0,053	20	-

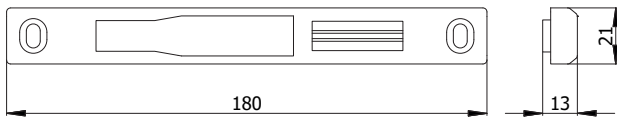

For locks series:

- 1300 - 1305
- 1400 - 1400S - 1405 - 1405S - 1408Q - 1409Q - 1410 - 1410S - 1415 - 1415S - 1418Q
- 1500 - 1500S - 1505 - 1505S - 1508Q
- 4400 - 4405 - 4408Q - 4409Q - 4410 - 4415 - 4418Q

For profiles type:

All.co 5

COD.	Material	kg		
02196 L	Painted special alloy	0,143	20	-

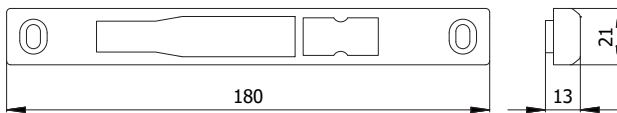

For locks series:

- 1408 - 1409 - 1418
- 1508
- 4408 - 4409 - 4418

For profiles type:

All.co 5

COD.	Material	kg		
02198 L	Painted special alloy	0,063	20	-

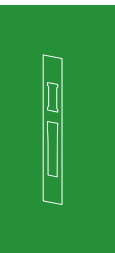

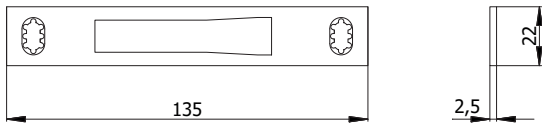

For locks series:

- 11141 - 11171
- 1401 - 1401S - 1411 - 1411S
- 1501 - 1501S
- 1941 - 1971
- 41141 - 41171
- 4401 - 4411
- 4941 - 4971
- 5931 - 5941 - 5948 - 5951 - 5961 - 5971 - 5978 - 5981

For deviators series:

- 0661 - 0661S - 0662

For deviators of multi-point locks with tipping dead bolt

For profiles type:

Domal Stopper PG Finestra
NC 45 Int. Finestra

COD.	Material			
02294 X	Stainless steel	0,052	50	-

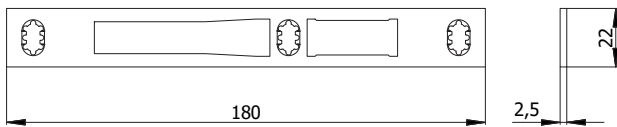

For locks series:

- 1300 - 1305
- 1400 - 1400S - 1405 - 1405S - 1408Q - 1409Q - 1410 - 1410S - 1415 - 1415S - 1418Q
- 1500 - 1500S - 1505 - 1505S - 1508Q
- 4400 - 4405 - 4408Q - 4409Q - 4410 - 4415 - 4418Q
- 5930 - 5935 - 5960 - 5965

For profiles type:

Domal Stopper PG Finestra
NC 45 Int. Finestra

COD.	Material			
02296 X	Stainless steel	0,068	50	-

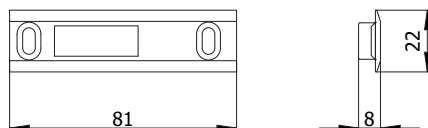

Roller bolt guide for striking plate:

02296 X

COD.	Material			
0645 N	Black nylon	0,004	10	-

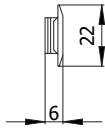
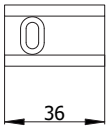

Insert for electric locks for striking plate:

02296 X

COD.	Material			
0648 N	Black nylon	0,002	10	-

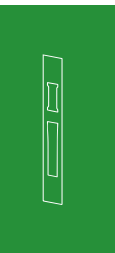

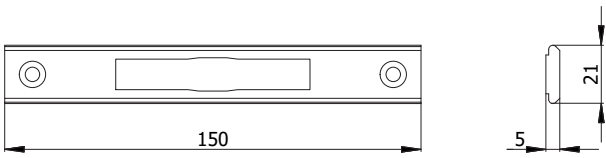

For locks series:

- 1301
- 1770 - 1771 - 1777 - 1780 - 1781 - 1785 - 1870
- 327 - 334 - 335 - 337 - 339 - 351 - 354 - 355 - 357 - 359
- 370 - 371 - 377 - 378 - 380 - 381 - 385 - 388
- 390 - 391 - 395 - 399
- 4335 - 4339 - 4355 - 4531
- 531 - 541
- 770 - 771 - 777 - 778 - 780 - 781 - 782 - 785 - 788
- 790 - 791 - 795 - 799
- 870 - 871 - 877 - 878 - 880 - 881 - 882 - 885 - 888
- 890 - 891 - 895 - 899
- 990 - 991 - 995 - 999

For profiles type:

Domal Stopper PG Finestra
NC 45 Int. Finestra

COD.	Material	kg		
02381 L	Aluminium	0,076	20	-

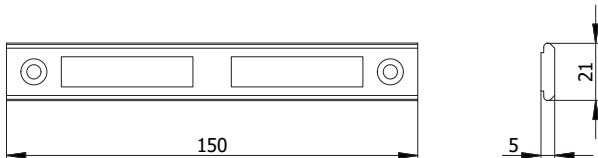

For locks series:

- 330 - 332 - 338 - 350 - 352 - 358
- 4330 - 4338 - 4350 - 4530
- 530 - 540

For profiles type:

Domal Stopper PG Finestra
NC 45 Int. Finestra

COD.	Material	kg		
02386 L	Aluminium	0,035	20	-

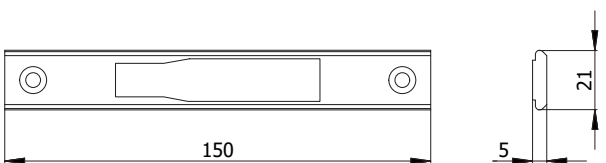

For locks series:

- 11141 - 11171
- 1401 - 1401S - 1411 - 1411S
- 1501 - 1501S
- 1941 - 1971
- 41141 - 41171
- 4401 - 4411
- 4941 - 4971
- 5931 - 5941 - 5948 - 5951 - 5961 - 5971 - 5978 - 5981

For deviators series:

- 0661 - 0661S - 0662

For deviators of multi-point locks with tipping dead bolt

For profiles type:

Domal Stopper PG Finestra
NC 45 Int. Finestra

COD.	Material	kg		
02394 L	Aluminium	0,035	20	-

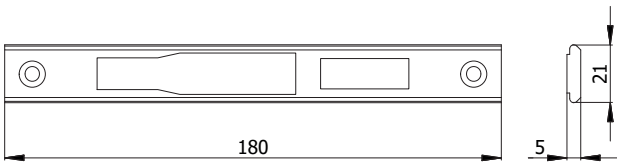

For locks series:

- 1300 - 1305
- 1400 - 1400S - 1405 - 1405S - 1408Q - 1409Q - 1410 - 1410S - 1415 - 1415S - 1418Q
- 1500 - 1500S - 1505 - 1505S - 1508Q
- 4400 - 4405 - 4408Q - 4409Q - 4410 - 4415 - 4418Q
- 5930 - 5935 - 5960 - 5965

For profiles type:

Domal Stopper PG Finestra
NC 45 Int. Finestra

COD.	Material	kg		
02396 L	Aluminium	0,038	20	-

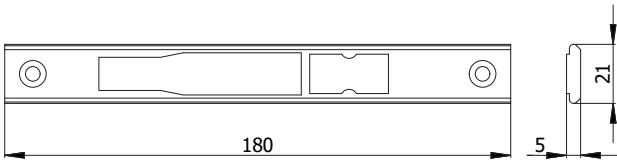

For locks series:

- 11140 - 11145 - 11170 - 11175
- 1408 - 1409 - 1418
- 1508
- 1940 - 1945 - 1970 - 1975
- 41140 - 41145 - 41170 - 41175
- 4408 - 4409 - 4418
- 4940 - 4945 - 4970 - 4975
- 5938 - 5940 - 5945 - 5950 - 5968 - 5970 - 5975 - 5980

For profiles type:

Domal Stopper PG Finestra
NC 45 Int. Finestra

COD.	Material	kg		
02398 L	Aluminium	0,038	20	-

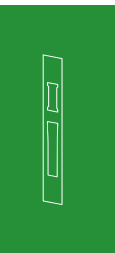

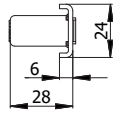
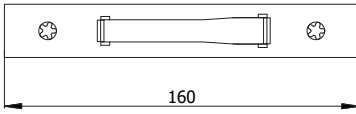

For locks series:

- 1401S - 1411S
- 1501S
- 1601S - 1611S - 1621S - 1631S
- 1701S - 1721S - 1741S - 1761S

For deviators series:

- 0661S - 0761S

For deviators of vertical multi-point locks with gear mechanism movements

(but series 1740S - 1760S)

COD.	Material			
02444 XU	Stainless steel	0,077	10	-

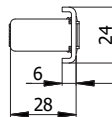
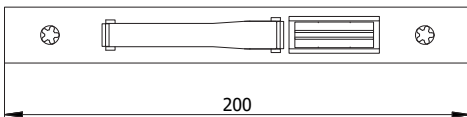

For locks series:

- 1400S - 1405S - 1410S - 1415S
- 1500S - 1505S
- 1600S - 1605S - 1610S - 1615S
- 1620S - 1625S - 1630S - 1635S
- 1700S - 1705S - 1720S - 1725S
- 1740S - 1745S - 1760S - 1765S

COD.	Material			
02446 XU	Stainless steel	0,089	10	-

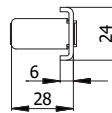
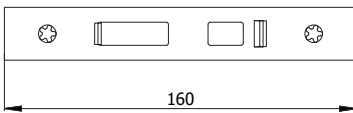

For deviators series:

- 0766S

For deviators of vertical multi-point locks with gear mechanism movements:

- 1740S - 1760S

COD.	Material			
02449 XU	Stainless steel	0,056	10	-

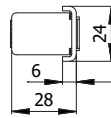
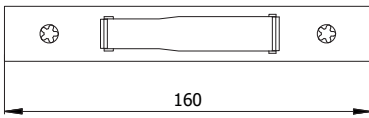

For locks series:

- 1401 - 1411
- 1491
- 1501
- 4401 - 4411
- 4491

For deviators series:

- 0661 - 0662

For deviators of multi-point locks with tipping dead bolt

COD.	Material	kg		
02494 XU	Stainless steel	0,084	10	-

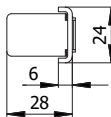
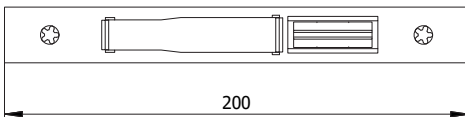

For locks series:

- 1400 - 1405 - 1410 - 1415
- 1490 - 1495
- 1500 - 1505
- 4400 - 4405 - 4410 - 4415
- 4490 - 4495

COD.	Material	kg		
02496 XU	Stainless steel	0,084	10	-

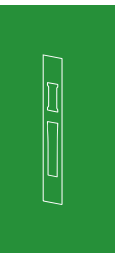

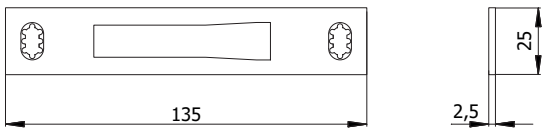

For locks series:

- 11141 - 11171
- 1401 - 1401S - 1411 - 1411S
- 1501 - 1501S
- 1941 - 1971
- 41141 - 41171
- 4401 - 4411
- 4941 - 4971
- 5931 - 5941 - 5948 - 5951 - 5961 - 5971 - 5978 - 5981

For deviators series:

- 0661 - 0661S - 0662

For deviators of multi-point locks with tipping dead bolt

COD.	Material	kg		
02594 X	Stainless steel	0,052	50	-

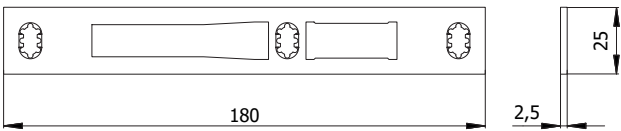

For locks series:

- 1300 - 1305
- 1400 - 1400S - 1405 - 1405S - 1408Q - 1409Q - 1410 - 1410S - 1415 - 1415S - 1418Q
- 1500 - 1500S - 1505 - 1505S - 1508Q
- 4400 - 4405 - 4408Q - 4409Q - 4410 - 4415 - 4418Q
- 5930 - 5935 - 5960 - 5965

COD.	Material	kg		
02596 X	Stainless steel	0,068	50	-

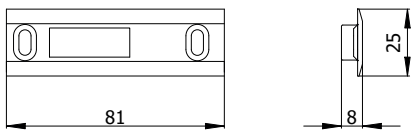

Roller bolt guide for striking plate:

02596 X

COD.	Material	kg		
0644 N	Black nylon	0,004	10	-

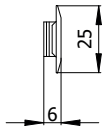
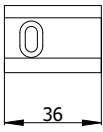

Insert for electric locks for striking plate:

02596 X

COD.	Material	kg		
0647 N	Black nylon	0,002	10	-

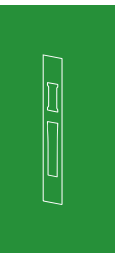

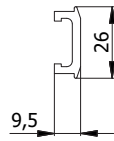
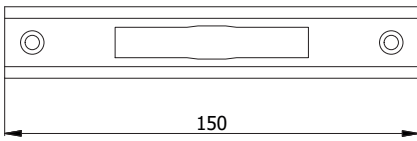

For locks series:

- 1301
- 1770 - 1771 - 1777 - 1780 - 1781 - 1785 - 1870
- 327 - 334 - 335 - 337 - 339 - 351 - 354 - 355 - 357 - 359
- 370 - 371 - 377 - 378 - 380 - 381 - 385 - 388
- 390 - 391 - 395 - 399
- 4335 - 4339 - 4355 - 4531
- 531 - 541
- 770 - 771 - 777 - 778 - 780 - 781 - 782 - 785 - 788
- 790 - 791 - 795 - 799
- 870 - 871 - 877 - 878 - 880 - 881 - 882 - 885 - 888
- 890 - 891 - 895 - 899
- 990 - 991 - 995 - 999

For profiles type:

Domal Break PA 52 Porta
NC 55 Int. Porta

COD.	Material	kg		
02681 L	Aluminium	0,056	10	-

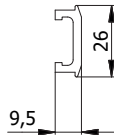
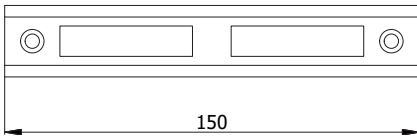

For locks series:

- 330 - 332 - 338 - 350 - 352 - 358
- 4330 - 4338 - 4350 - 4530
- 530 - 540

For profiles type:

Domal Break PA 52 Porta
NC 55 Int. Porta

COD.	Material	kg		
02686 L	Aluminium	0,053	10	-

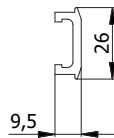
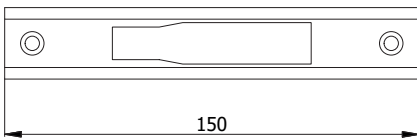

For locks series:

- 11141 - 11171
- 1401 - 1401S - 1411 - 1411S
- 1501 - 1501S
- 1941 - 1971
- 41141 - 41171
- 4401 - 4411
- 4941 - 4971
- 5931 - 5941 - 5948 - 5951 - 5961 - 5971 - 5978 - 5981

For deviators series:

- 0661 - 0661S - 0662

For deviators of multi-point locks with tipping dead bolt

For profiles type:

Domal Break PA 52 Porta
NC 55 Int. Porta

COD.	Material	kg		
02694 L	Aluminium	0,053	10	-

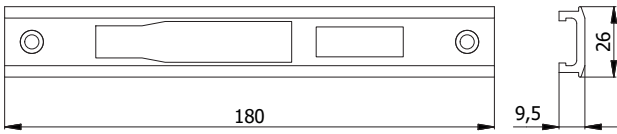

For locks series:

- 1300 - 1305
- 1400 - 1400S - 1405 - 1405S - 1408Q - 1409Q - 1410 - 1410S - 1415 - 1415S - 1418Q
- 1500 - 1500S - 1505 - 1505S - 1508Q
- 4400 - 4405 - 4408Q - 4409Q - 4410 - 4415 - 4418Q
- 5930 - 5935 - 5960 - 5965

For profiles type:

Domal Break PA 52 Porta
NC 55 Int. Porta

COD.	Material	kg		
02696 L	Aluminium	0,060	10	-

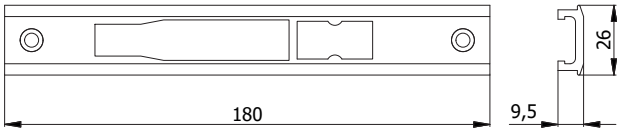

For locks series:

- 11140 - 11145 - 11170 - 11175
- 1408 - 1409 - 1418
- 1508
- 1940 - 1945 - 1970 - 1975
- 41140 - 41145 - 41170 - 41175
- 4408 - 4409 - 4418
- 4940 - 4945 - 4970 - 4975
- 5938 - 5940 - 5945 - 5950 - 5968 - 5970 - 5975 - 5980

For profiles type:

Domal Break PA 52 Porta
NC 55 Int. Porta

COD.	Material	kg		
02698 L	Aluminium	0,059	10	-

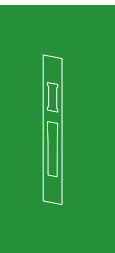

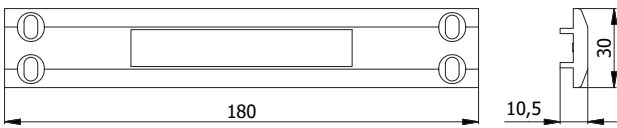

For locks series:

- 11140 - 11141 - 11145 - 11170 - 11171 - 11175
- 1940 - 1941 - 1945 - 1970 - 1971 - 1975
- 41140 - 41141 - 41145 - 41170 - 41171 - 41175
- 4940 - 4941 - 4945 - 4970 - 4971 - 4975
- 5930 - 5931 - 5935 - 5938 - 5940 - 5941 - 5945 - 5948
- 5950 - 5951 - 5960 - 5961 - 5965 - 5968 - 5970 - 5971
- 5975 - 5978 - 5980 - 5981

For profiles type:

R 40, R 50

COD.	Material			
02821 L	Painted special alloy	0,133	20	-

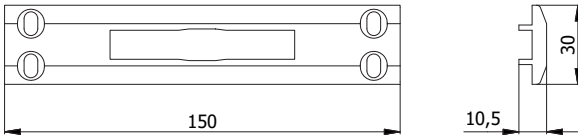

For locks series:

- 1301
- 1770 - 1771 - 1777 - 1780 - 1781 - 1785 - 1870
- 327 - 334 - 335 - 337 - 339 - 351 - 354 - 355 - 357 - 359
- 370 - 371 - 377 - 378 - 380 - 381 - 385 - 388
- 390 - 391 - 395 - 399
- 4335 - 4339 - 4355 - 4531
- 531 - 541
- 770 - 771 - 777 - 778 - 780 - 781 - 782 - 785 - 788
- 790 - 791 - 795 - 799
- 870 - 871 - 877 - 878 - 880 - 881 - 882 - 885 - 888
- 890 - 891 - 895 - 899
- 990 - 991 - 995 - 999

For profiles type:

R 40, R 50

COD.	Material			
02881 L	Painted special alloy	0,118	20	-

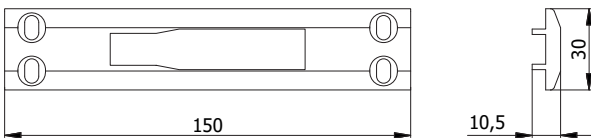

For locks series:

- 1401 - 1401S - 1411 - 1411S
- 1501 - 1501S
- 4401 - 4411

For deviators series:

- 0661 - 0661S - 0662

For deviators of multi-point locks with tipping dead bolt

For profiles type:

R 40, R 50

COD.	Material			
02894 L	Painted special alloy	0,112	20	-

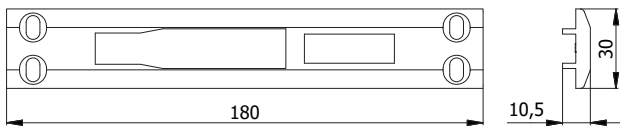

For locks series:

1300 - 1305
 1400 - 1400S - 1405 - 1405S - 1408Q - 1409Q - 1410 - 1410S
 1415 - 1415S - 1418Q
 1500 - 1500S - 1505 - 1505S - 1508Q
 4400 - 4405 - 4408Q - 4409Q - 4410 - 4415 - 4418Q

For profiles type:

R 40, R 50

COD.	Material	kg		
02896 L	Painted special alloy	0,119	20	-

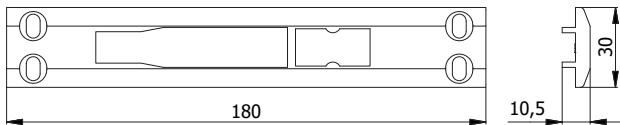

For locks series:

1408 - 1409 - 1418
 1508
 4408 - 4409 - 4418

For profiles type:

R 40, R 50

COD.	Material	kg		
02898 L	Painted special alloy	0,127	20	-

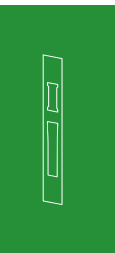

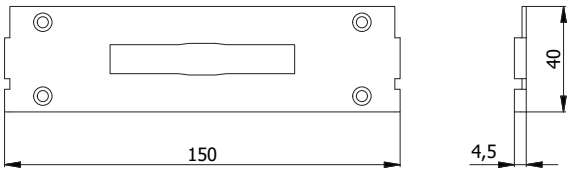

For locks series:

- 1301
- 1770 - 1771 - 1777 - 1780 - 1781 - 1785 - 1870
- 327 - 334 - 335 - 337 - 339 - 351 - 354 - 355 - 357 - 359
- 370 - 371 - 377 - 378 - 380 - 381 - 385 - 388
- 390 - 391 - 395 - 399
- 4335 - 4339 - 4355 - 4531
- 531 - 541
- 770 - 771 - 777 - 778 - 780 - 781 - 782 - 785 - 788
- 790 - 791 - 795 - 799
- 870 - 871 - 877 - 878 - 880 - 881 - 882 - 885 - 888
- 890 - 891 - 895 - 899
- 990 - 991 - 995 - 999

For profiles type:

NC 40

COD.	Material	kg		
04061 A	Plastic plated steel	0,060	50	-

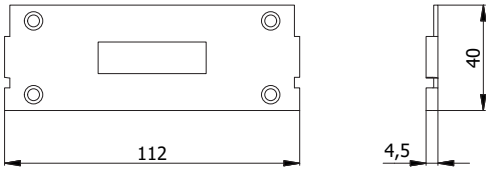

For locks series:

- 1301
- 1771 - 1777 - 1780 - 1781 - 1785
- 327 - 337 - 351 - 357
- 371 - 377 - 380 - 381 - 385 - 388 - 390 - 391 - 395 - 399
- 771 - 777 - 780 - 781 - 785 - 788 - 790 - 791 - 795 - 799
- 871 - 877 - 880 - 881 - 885 - 888 - 890 - 891 - 895 - 899
- 990 - 991 - 995 - 999

For profiles type:

NC 40

COD.	Material	kg		
04063 A	Plastic plated steel	0,046	50	-

SERIES 023 X

For profiles type:

- Camera Europea serie Finestra
- Domal Stopper PG Finestra
- NC 45 Int. Finestra
- Export 45 Finestra
- Nuovo NC 40 Sormonto 1 anta

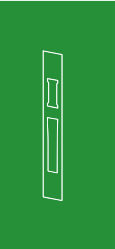
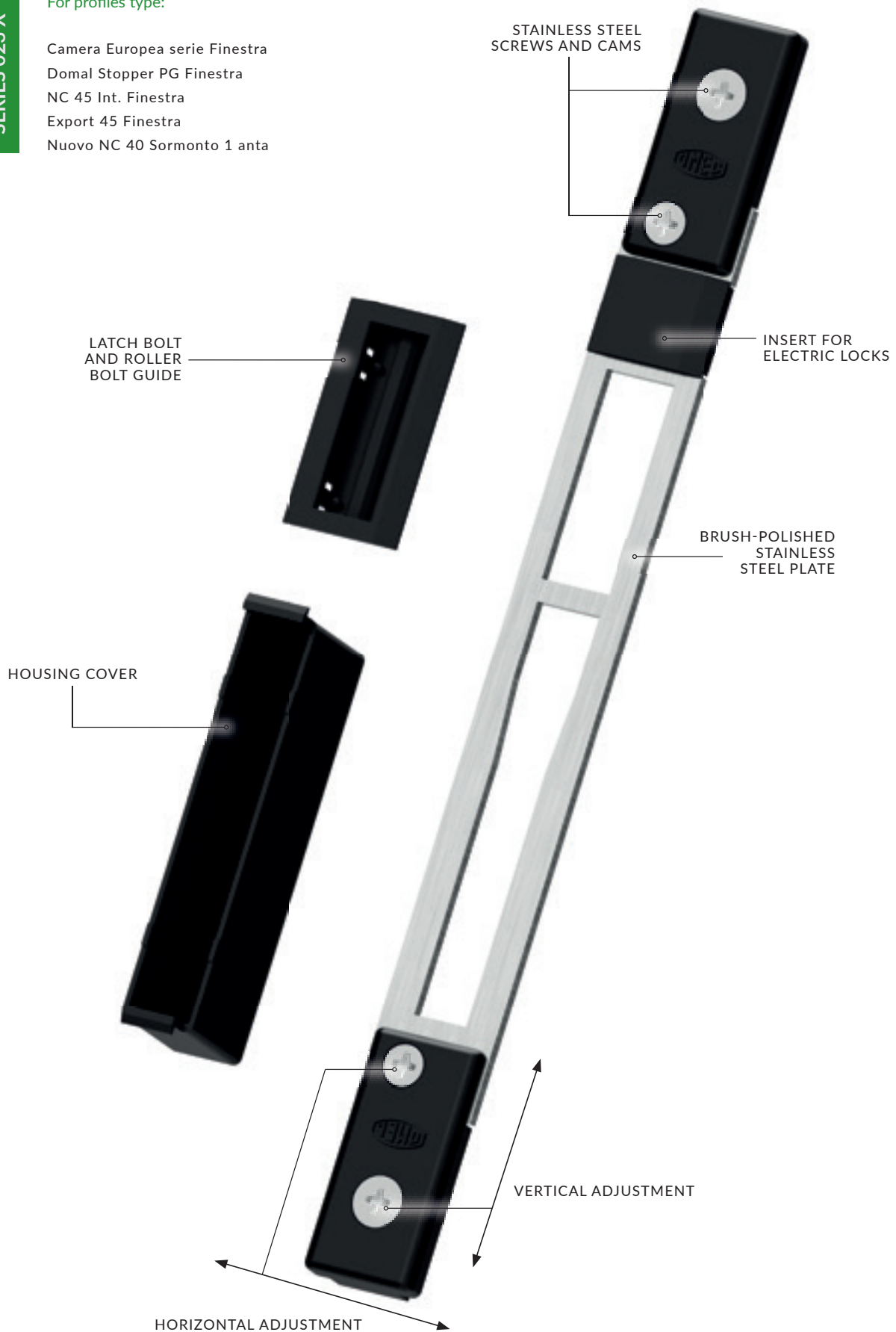

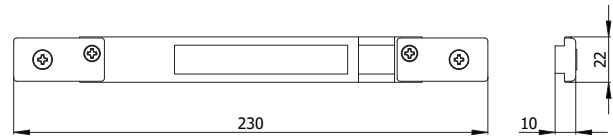

For locks series:

- 11140 - 11141 - 11145 - 11170 - 11171 - 11175
- 1940 - 1941 - 1945 - 1970 - 1971 - 1975
- 41140 - 41141 - 41145 - 41170 - 41171 - 41175
- 4940 - 4941 - 4945 - 4970 - 4971 - 4975
- 5930 - 5931 - 5935 - 5938 - 5940 - 5941 - 5945 - 5948
- 5950 - 5951 - 5960 - 5961 - 5965 - 5968 - 5970 - 5971
- 5975 - 5978 - 5980 - 5981

For profiles type:

Domal stopper PG Finestra
NC 45 Int. Finestra

COD.	Material	kg		
02321 X	Stainless steel	0,126	10	-

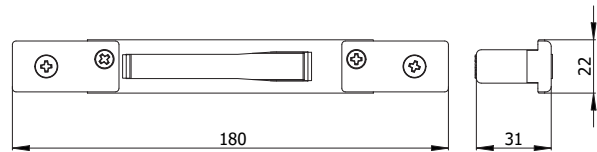

For locks series:

- 1401S - 1411S
- 1501S
- 1601S - 1611S - 1621S - 1631S
- 1701S - 1721S - 1741S - 1761S

For deviators series:

- 0661S - 0761S

For deviators of vertical multi-point locks with gear mechanism movements (but series 1740S - 1760S)

For profiles type:

Domal stopper PG Finestra
NC 45 Int. Finestra

COD.	Material	kg		
02344 X	Stainless steel	0,123	10	-

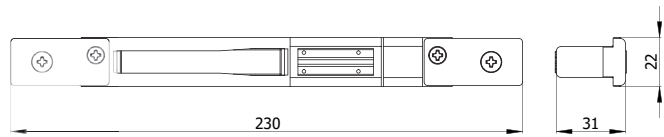

For locks series:

- 1400S - 1405S - 1410S - 1415S
- 1500S - 1505S
- 1600S - 1605S - 1610S - 1615S
- 1620S - 1625S - 1630S - 1635S
- 1700S - 1705S - 1720S - 1725S
- 1740S - 1745S - 1760S - 1765S

For profiles type:

Domal stopper PG Finestra
NC 45 Int. Finestra

COD.	Material	kg		
02346 X	Stainless steel	0,138	10	-

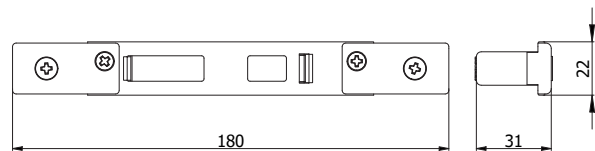

For deviators series:

0766S

For deviators of vertical multi-point locks with gear mechanism movements:

1740S - 1760S

For profiles type:

Domal stopper PG Finestra
NC 45 Int. Finestra

COD.	Material	kg		
02349 X	Stainless steel	0,138	10	-

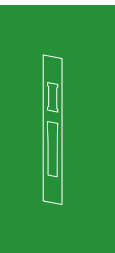

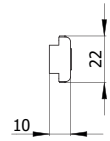
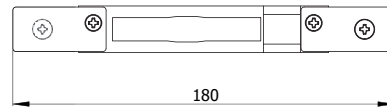

For locks series:

- 1301
- 1770 - 1771 - 1775 - 1777 - 1780 - 1781 - 1785 - 1870
- 327 - 334 - 335 - 337 - 339 - 351 - 354 - 355 - 357 - 359
- 370 - 371 - 375 - 377 - 378 - 380 - 381 - 385 - 388
- 390 - 391 - 395 - 399
- 4335 - 4339 - 4355 - 4531
- 531 - 541
- 770 - 771 - 775 - 777 - 778 - 780 - 781 - 782 - 785 - 788
- 790 - 791 - 795 - 799
- 870 - 871 - 875 - 877 - 878 - 880 - 881 - 882 - 885 - 888
- 890 - 891 - 895 - 899
- 990 - 991 - 995 - 999

For profiles type:

Domal stopper PG Finestra
NC 45 Int. Finestra

COD.	Material	kg		
02381 X	Stainless steel	0,112	10	-

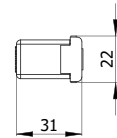
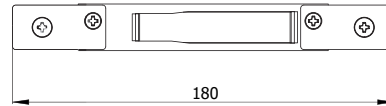

For locks series:

- 1401 - 1411
- 1501
- 4401 - 4411

For deviators series:

- 0661 - 0662

For deviators of multi-point locks with tipping dead bolt

For profiles type:

Domal stopper PG Finestra
NC 45 Int. Finestra

COD.	Material	kg		
02394 X	Stainless steel	0,118	10	-

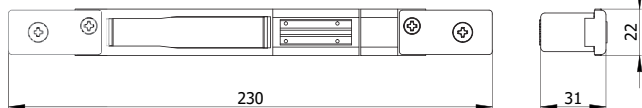

For locks series:

- 1300-1305
- 1400-1405-1408-1408Q-1409-1409Q-1410-1415-1418-1418Q
- 1500-1505-1508-1508Q
- 320-322-328-330-332-338-340-342-345-348-350-352-358
- 4320-4328-4330-4338-4340-4350
- 4400-4405-4408-4408Q-4409-4409Q-4410-4415-4418-4418Q
- 4530-4535
- 530-535-540-545

For profiles type:

Domal stopper PG Finestra
NC 45 Int. Finestra

COD.	Material	kg		
02396 X	Stainless steel	0,133	10	-



SERIES 026 X

For profiles type:

- Domal Break Porte 52
- NC65 STH Porte
- Export 50TT Porte
- ALU - K 62TT Porte

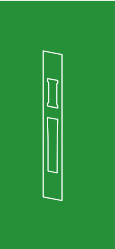
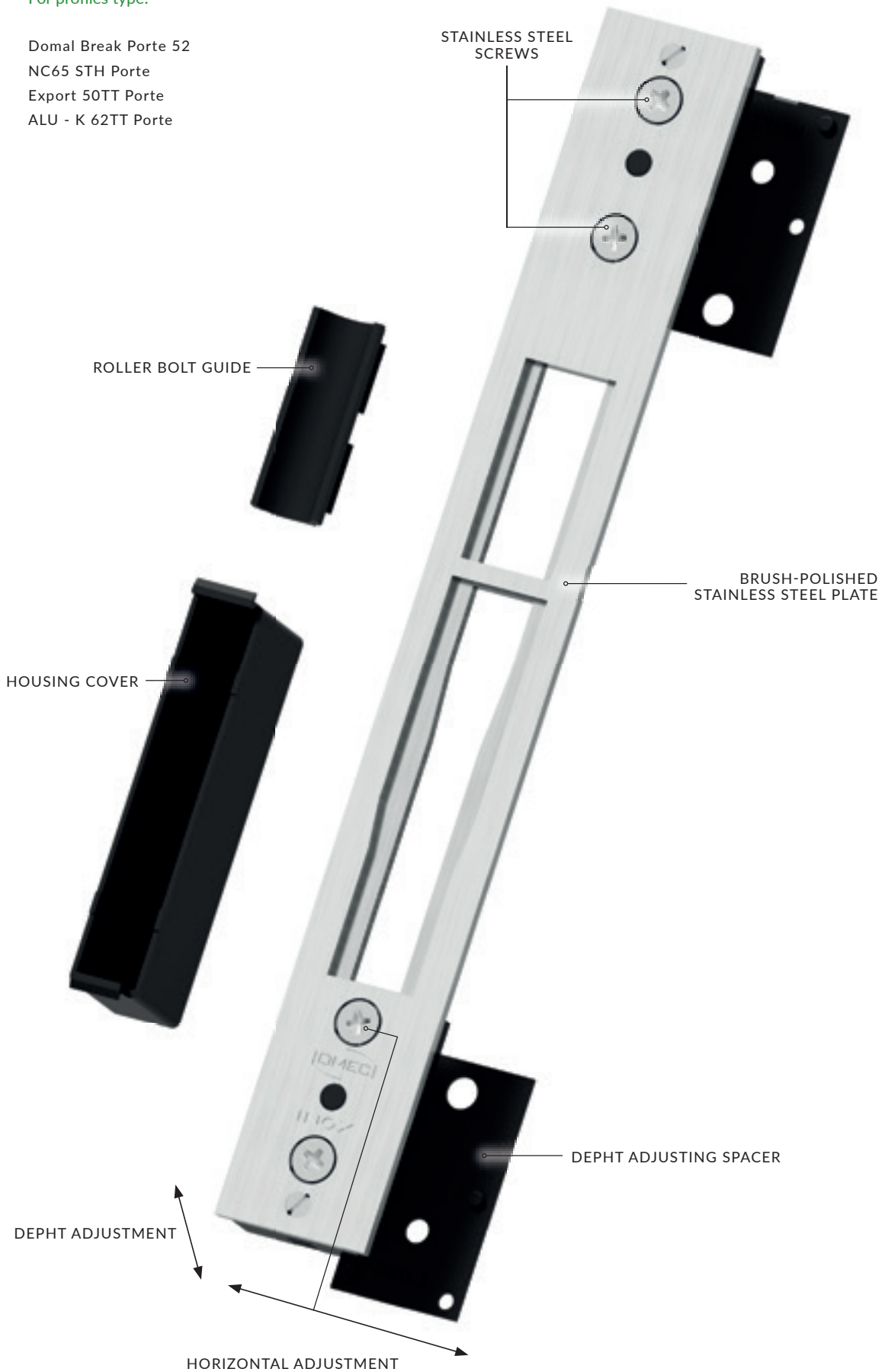

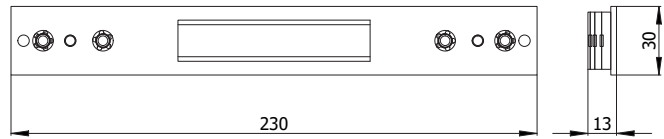

For locks series:

- 11140 - 11141 - 11145 - 11170 - 11171 - 11175
- 1940 - 1941 - 1945 - 1970 - 1971 - 1975
- 41140 - 41141 - 41145 - 41170 - 41171 - 41175
- 4940 - 4941 - 4945 - 4970 - 4971 - 4975
- 5930 - 5931 - 5935 - 5938 - 5940 - 5941 - 5945 - 5948
- 5950 - 5951 - 5960 - 5961 - 5965 - 5968 - 5970 - 5971
- 5975 - 5978 - 5980 - 5981

For profiles type:

- Domal Break PA 52 Porta
- Domal stopper PG Porta
- NC 55 Int. Porta
- NC 45 Int. Porta

COD.	Material	kg		
02621 X	Stainless steel	0,193	10	-

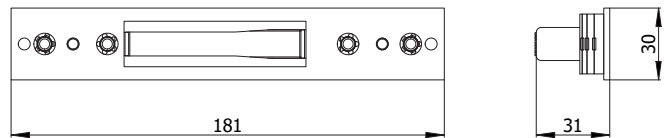

For locks series:

- 1401S - 1411S
- 1501S
- 1601S - 1611S - 1621S - 1631S
- 1701S - 1721S - 1741S - 1761S

For deviators series:

- 0661S - 0761S

For deviators of vertical multi-point locks with gear mechanism movements (but series 1740S - 1760S)

For profiles type:

- Domal Break PA 52 Porta
- Domal stopper PG Porta
- NC 55 Int. Porta
- NC 45 Int. Porta

COD.	Material	kg		
02644 X	Stainless steel	0,160	10	-

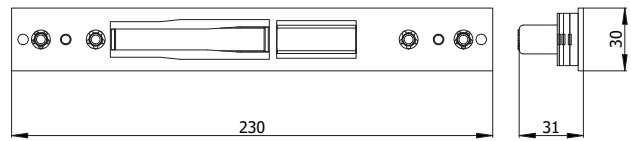

For locks series:

- 1400S - 1405S - 1410S - 1415S
- 1500S - 1505S
- 1600S - 1605S - 1610S - 1615S
- 1620S - 1625S - 1630S - 1635S
- 1700S - 1705S - 1720S - 1725S
- 1740S - 1745S - 1760S - 1765S

For profiles type:

- Domal Break PA 52 Porta
- Domal stopper PG Porta
- NC 55 Int. Porta
- NC 45 Int. Porta

COD.	Material	kg		
02646 X	Stainless steel	0,188	10	-

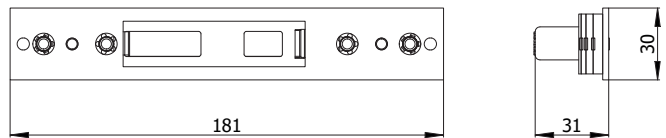

For deviators series:

0766S

For deviators of vertical multi-point locks with gear mechanism movements:

1740S - 1760S

For profiles type:

- Domal Break PA 52 Porta
- Domal stopper PG Porta
- NC 55 Int. Porta
- NC 45 Int. Porta

COD.	Material	kg		
02649 X	Stainless steel	0,188	10	-



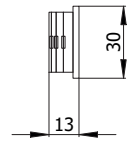
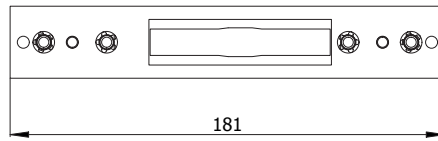

For locks series:

- 1301
- 1770 - 1771 - 1775 - 1777 - 1780 - 1781 - 1785 - 1870
- 327 - 334 - 335 - 337 - 339 - 351 - 354 - 355 - 357 - 359
- 370 - 371 - 375 - 377 - 378 - 380 - 381 - 385 - 388
- 390 - 391 - 395 - 399
- 4335 - 4339 - 4355 - 4531
- 531 - 541
- 770 - 771 - 775 - 777 - 778 - 780 - 781 - 782 - 785 - 788
- 790 - 791 - 795 - 799
- 870 - 871 - 875 - 877 - 878 - 880 - 881 - 882 - 885 - 888
- 890 - 891 - 895 - 899
- 990 - 991 - 995 - 999

For profiles type:

- Domal Break PA 52 Porta
- Domal stopper PG Porta
- NC 55 Int. Porta
- NC 45 Int. Porta

COD.	Material	kg		
02681 X	Stainless steel	0,150	10	-

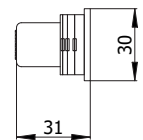
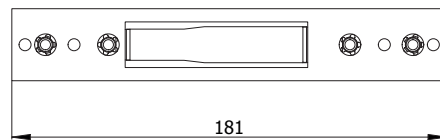

For locks series:

- 1401 - 1411
- 1501
- 4401 - 4411

For deviators series:

- 0661 - 0662

For deviators of multi-point locks with tipping dead bolt

For profiles type:

- Domal Break PA 52 Porta
- Domal stopper PG Porta
- NC 55 Int. Porta
- NC 45 Int. Porta

COD.	Material	kg		
02694 X	Stainless steel	0,155	10	-

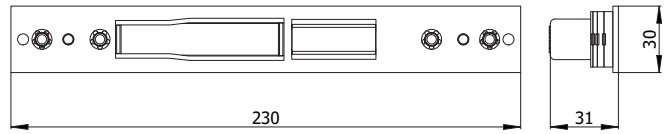

For locks series:

1300-1305
 1400-1405-1408-1408Q-1409-1409Q-1410-1415-1418-1418Q
 1500-1505-1508-1508Q
 320-322-328-330-332-338-340-342-345-348-350-352-358
 4320-4328-4330-4338-4340-4350
 4400-4405-4408-4408Q-4409-4409Q-4410-4415-4418-4418Q
 4530-4535
 530-535-540-545

For profiles type:

Domal Break PA 52 Porta
 Domal stopper PG Porta
 NC 55 Int. Porta
 NC 45 Int. Porta

COD.	Material	kg		
02696 X	Stainless steel	0,183	10	-

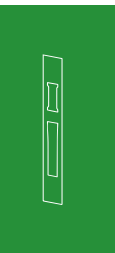

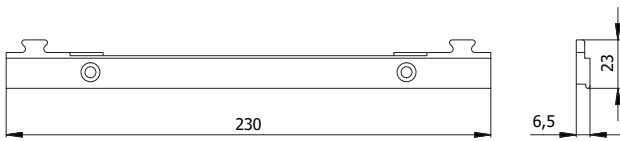

Lateral spacer for striking plates cod.

02621 X - 02646 X - 02696 X

For external opening door profiles type:

NC 65 STH
ALUK 62 TT
Euro Line 60

COD.	Material	kg		
0740 N	Black nylon	0,026	10	-

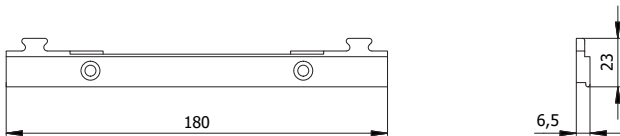

Lateral spacer for striking plates cod.

02644 X - 02649 X - 02681 X - 02694 X

For external opening door profiles type:

NC 65 STH
ALUK 62 TT
Euro Line 60

COD.	Material	kg		
0741 N	Black nylon	0,022	10	-

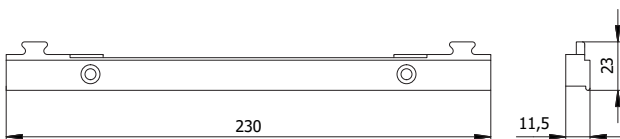

Lateral spacer for striking plates cod.

02621 X - 02646 X - 02696 X

For external opening door profiles type:

Domal Break 52
NC 55 TH
Export 50 TT

COD.	Material	kg		
0742 N	Black nylon	0,038	10	-

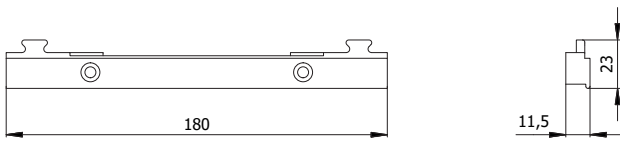

Lateral spacer for striking plates cod.

02644 X - 02649 X - 02681 X - 02694 X

For external opening door profiles type:

Domal Break 52
NC 55 TH
Export 50 TT

COD.	Material	kg		
0743 N	Black nylon	0,032	10	-

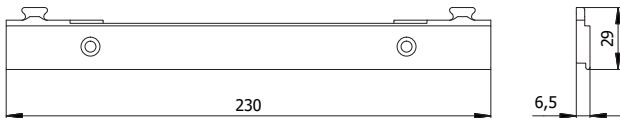

Lateral spacer for striking plates cod.

02621 X - 02646 X - 02696 X

For external opening door profiles type:

ALUK 67IW

COD.	Material	kg		
0744 N	Black nylon	0,034	10	-

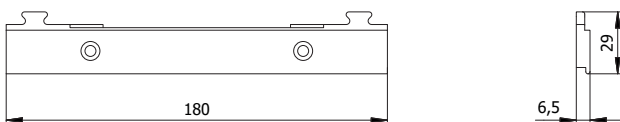

Lateral spacer for striking plates cod.

02644 X - 02649 X - 02681 X - 02694 X

For external opening door profiles type:

ALUK 67IW

COD.	Material	kg		
0745 N	Black nylon	0,028	10	-

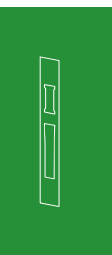

SERIES 028 X

For profiles type:

- R 40
- R 50
- NEW - TEC

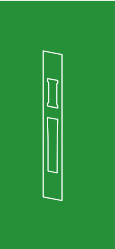
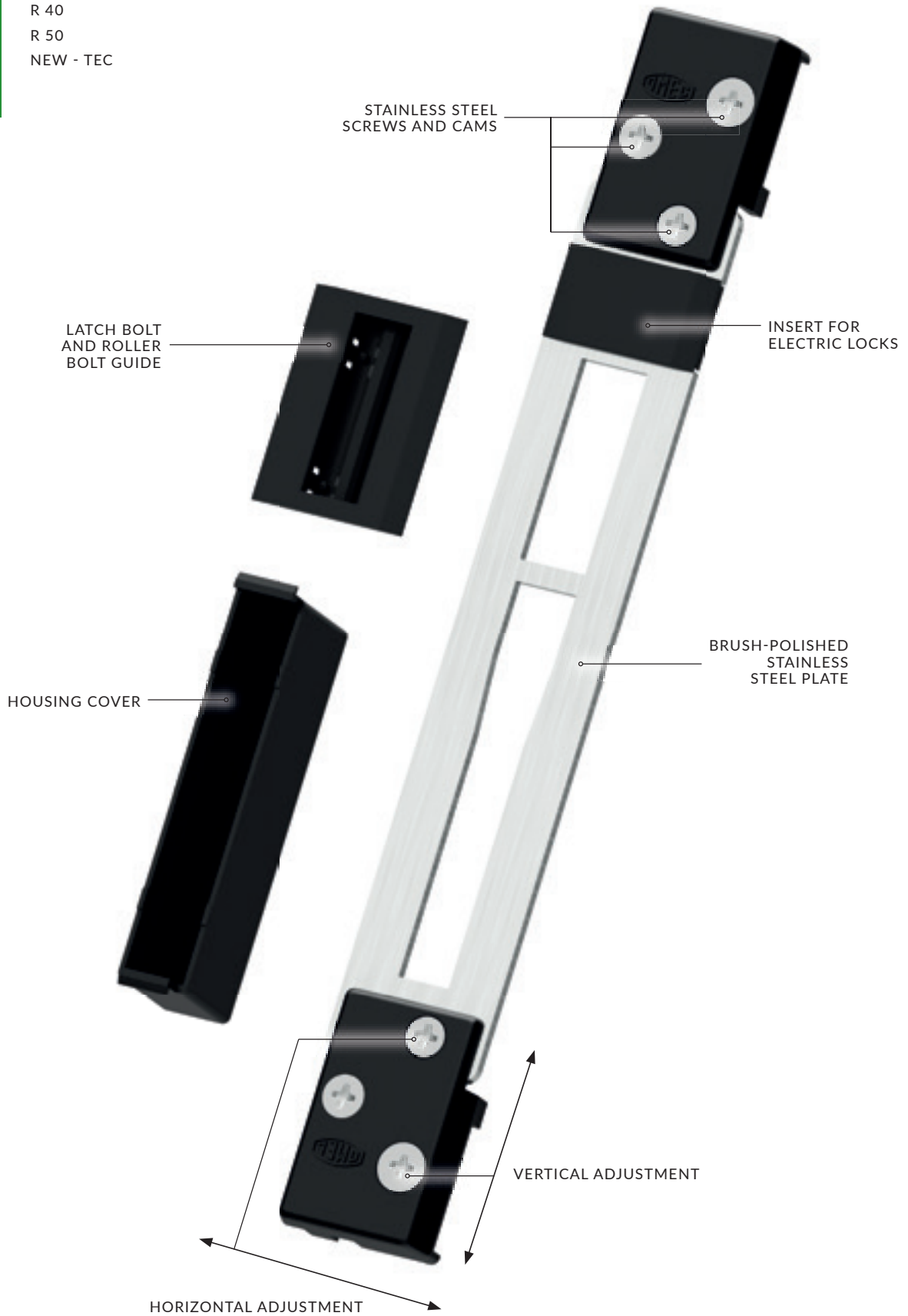

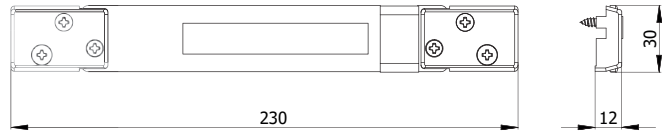

For locks series:

- 11140 - 11141 - 11145 - 11170 - 11171 - 11175
- 1940 - 1941 - 1945 - 1970 - 1971 - 1975
- 41140 - 41141 - 41145 - 41170 - 41171 - 41175
- 4940 - 4941 - 4945 - 4970 - 4971 - 4975
- 5930 - 5931 - 5935 - 5938 - 5940 - 5941 - 5945 - 5948
- 5950 - 5951 - 5960 - 5961 - 5965 - 5968
- 5970 - 5971 - 5975 - 5978 - 5980 - 5981

For profiles type:

R 40, R 50

COD.	Material	kg		
02821 X	Stainless steel	0,180	10	-

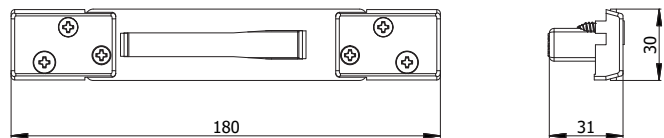

For locks series:

- 1401S - 1411S
- 1501S
- 1601S - 1611S - 1621S - 1631S
- 1701S - 1721S - 1741S - 1761S

For deviators series:

- 0661S - 0761S

For deviators of vertical multi-point locks with gear mechanism movements (but series 1740S - 1760S)

For profiles type:

R 40, R 50

COD.	Material	kg		
02844 X	Stainless steel	0,165	10	-

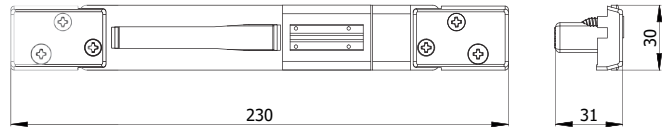

For locks series:

- 1400S - 1405S - 1410S - 1415S
- 1500S - 1505S
- 1600S - 1605S - 1610S - 1615S
- 1620S - 1625S - 1630S - 1635S
- 1700S - 1705S - 1720S - 1725S
- 1740S - 1745S - 1760S - 1765S

For profiles type:

R 40, R 50

COD.	Material	kg		
02846 X	Stainless steel	0,190	10	-

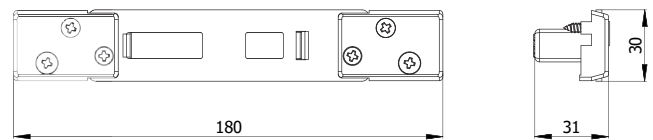

For deviators series:

0766S

For deviators of vertical multi-point locks with gear mechanism movements:

1740S - 1760S

For profiles type:

R 40, R 50

COD.	Material	kg		
02849 X	Stainless steel	0,190	10	-

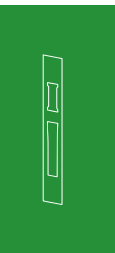

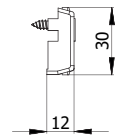
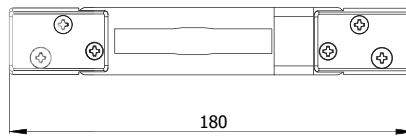

For locks series:

- 1301
- 1770 - 1771 - 1775 - 1777 - 1780 - 1781 - 1785 - 1870
- 327 - 334 - 335 - 337 - 339 - 351 - 354 - 355 - 357 - 359
- 370 - 371 - 375 - 377 - 378 - 380 - 381 - 385 - 388
- 390 - 391 - 395 - 399
- 4335 - 4339 - 4355 - 4531
- 531 - 541
- 770 - 771 - 775 - 777 - 778 - 780 - 781 - 782 - 785 - 788
- 790 - 791 - 795 - 799
- 870 - 871 - 875 - 877 - 878 - 880 - 881 - 882 - 885 - 888
- 890 - 891 - 895 - 899
- 990 - 991 - 995 - 999

For profiles type:

R 40, R 50

COD.	Material	kg		
02881 X	Stainless steel	0,154	10	-

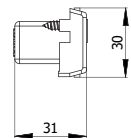
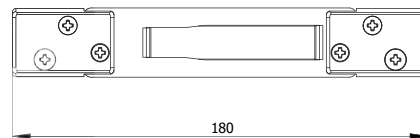

For locks series:

- 1401 - 1411
- 1501
- 4401 - 4411

For deviators series:

- 0661 - 0662

For deviators of multi-point locks with tipping dead bolt

For profiles type:

R 40, R 50

COD.	Material	kg		
02894 X	Stainless steel	0,160	10	-

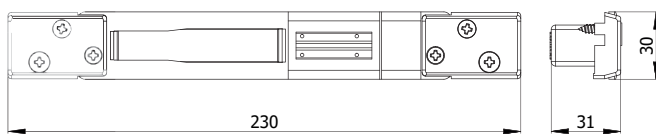

For locks series:

- 1300-1305
- 1400-1405-1408-1408Q-1409-1409Q-1410-1415-1418-1418Q
- 1500-1505-1508-1508Q
- 320-322-328-330-332-338-340-342-345-348-350-352-358
- 4320-4328-4330-4338-4340-4350
- 4400-4405-4408-4408Q-4409-4409Q-4410-4415-4418-4418Q
- 4530-4535
- 530-535-540-545

For profiles type:

R 40, R 50

COD.	Material	kg		
02896 X	Stainless steel	0,185	10	-



SERIES 030X

For profiles type:

All.co 5 Sormonto

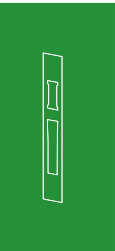
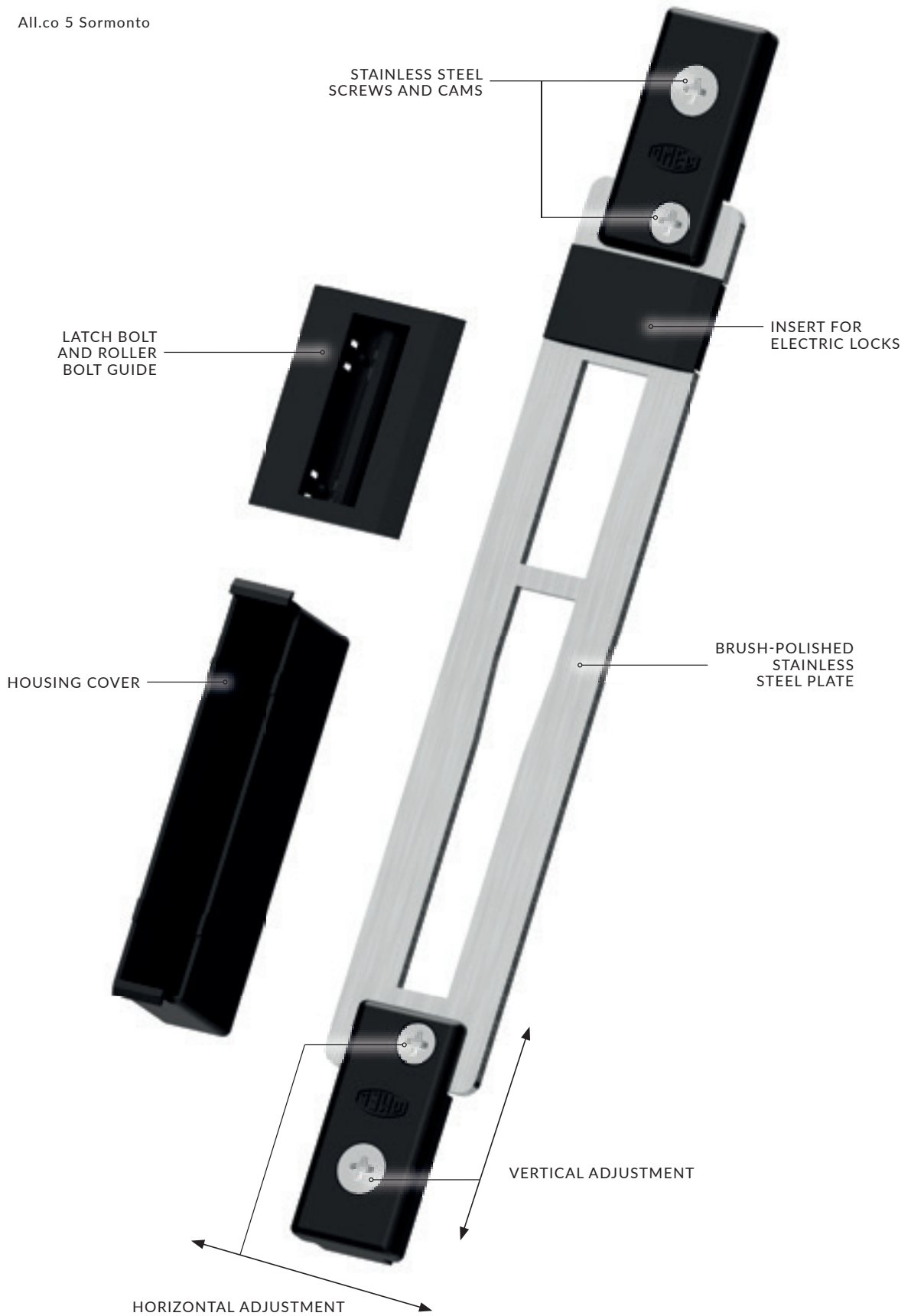

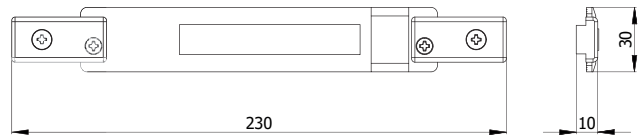

For locks series:

- 11140 - 11141 - 11145 - 11170 - 11171 - 11175
- 1940 - 1941 - 1945 - 1970 - 1971 - 1975
- 41140 - 41141 - 41145 - 41170 - 41171 - 41175
- 4940 - 4941 - 4945 - 4970 - 4971 - 4975
- 5930 - 5931 - 5935 - 5938 - 5940 - 5941 - 5945 - 5948
- 5950 - 5951 - 5960 - 5961 - 5965 - 5968 - 5970 - 5971
- 5975 - 5978 - 5980 - 5981

For profiles type:

All.co 5 Sormonto

COD.	Material	kg		
03021 X	Stainless steel	0,148	10	-

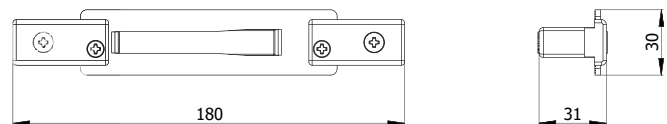

For locks series:

- 1401S - 1411S
- 1501S
- 1601S - 1611S - 1621S - 1631S
- 1701S - 1721S - 1741S - 1761S

For deviators series:

- 0661S - 0761S

For deviators of vertical multi-point locks with gear mechanism movements (but series 1740S - 1760S)

For profiles type:

All.co 5 Sormonto

COD.	Material	kg		
03044 X	Stainless steel	0,137	10	-

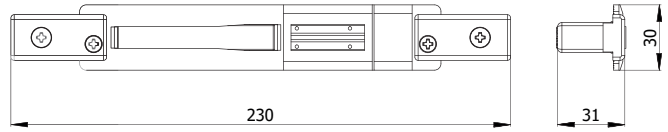

For locks series:

- 1400S - 1405S - 1410S - 1415S
- 1500S - 1505S
- 1600S - 1605S - 1610S - 1615S
- 1620S - 1625S - 1630S - 1635S
- 1700S - 1705S - 1720S - 1725S
- 1740S - 1745S - 1760S - 1765S

For profiles type:

All.co 5 Sormonto

COD.	Material	kg		
03046 X	Stainless steel	0,165	10	-

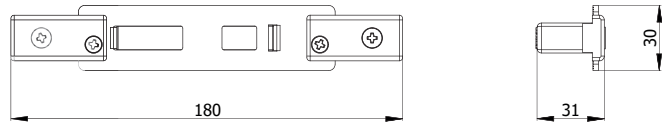

For deviators series:

0766S

For deviators of vertical multi-point locks with gear mechanism movements:

1740S - 1760S

For profiles type:

All.co 5 Sormonto

COD.	Material	kg		
03049 X	Stainless steel	0,165	10	-

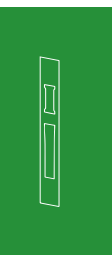

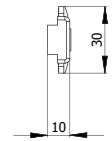
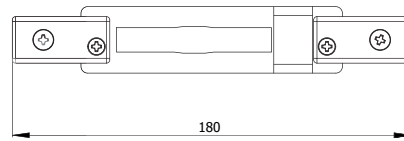

For locks series:

- 1301
- 1770 - 1771 - 1775 - 1777 - 1780 - 1781 - 1785 - 1870
- 327 - 334 - 335 - 337 - 339 - 351 - 354 - 355 - 357 - 359
- 370 - 371 - 375 - 377 - 378 - 380 - 381 - 385 - 388
- 390 - 391 - 395 - 399
- 4335 - 4339 - 4355 - 4531
- 531 - 541
- 770 - 771 - 775 - 777 - 778 - 780 - 781 - 782 - 785 - 788
- 790 - 791 - 795 - 799
- 870 - 871 - 875 - 877 - 878 - 880 - 881 - 882 - 885 - 888
- 890 - 891 - 895 - 899
- 990 - 991 - 995 - 999

For profiles type:

All.co 5 Sormonto

COD.	Material	kg		
03081 X	Stainless steel	0,128	10	-

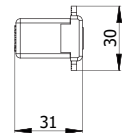
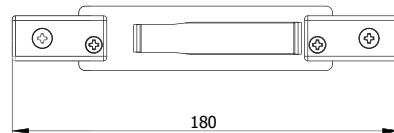

For locks series:

- 1401 - 1411
- 1501
- 4401 - 4411

For deviators series:

- 0661 - 0662

For deviators of multi-point locks with tipping dead bolt

For profiles type:

All.co 5 Sormonto

COD.	Material	kg		
03094 X	Stainless steel	0,132	10	-

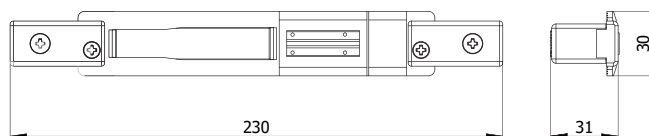

For locks series:

- 1300-1305
- 1400-1405-1408-1408Q-1409-1409Q-1410-1415-1418-1418Q
- 1500-1505-1508-1508Q
- 320-322-328-330-332-338-340-342-345-348-350-352-358
- 4320-4328-4330-4338-4340-4350
- 4400-4405-4408-4408Q-4409-4409Q-4410-4415-4418-4418Q
- 4530-4535
- 530-535-540-545

For profiles type:

All.co 5 Sormonto

COD.	Material	kg		
03096 X	Stainless steel	0,160	10	-

